

Data Center PowerPOD 3.0 Technology

White Paper

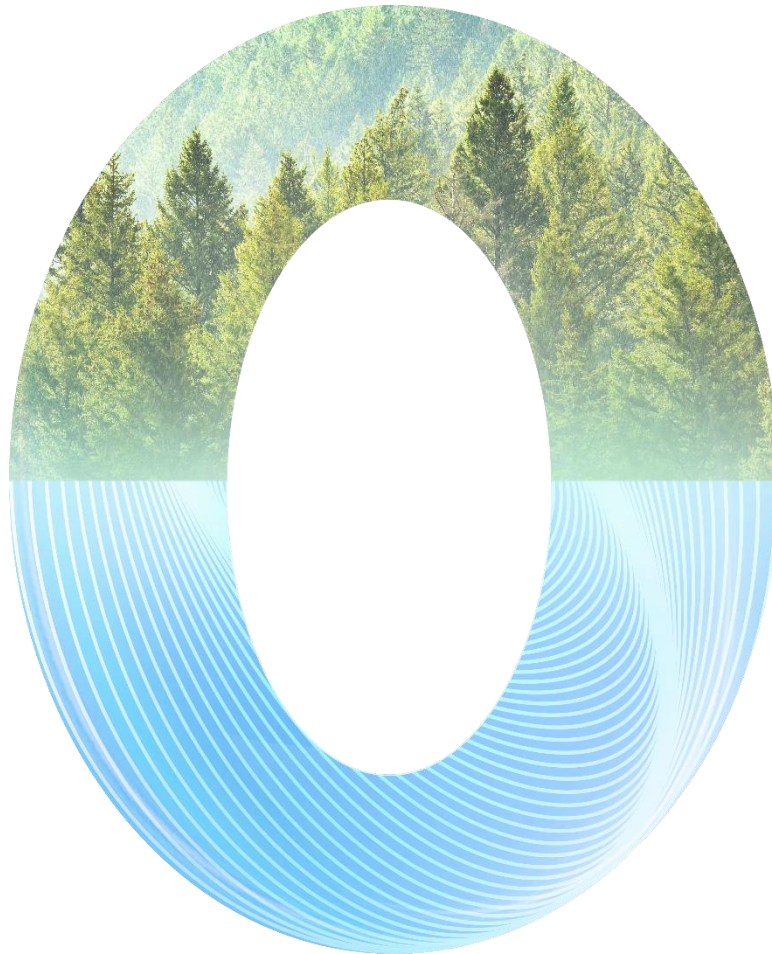

1. Preface

With the rapid development of 5G, cloud computing, Internet of Everything (IoE), and unmanned driving, large data centers have become a focus of new infrastructure construction. As basic strategic resources of a country, large data centers have been considered part of strategic commanding points in building the country's competitiveness. The construction scale and quantity of data centers are increasing rapidly.

The traditional power supply systems of data centers face a number of challenges, such as a large footprint, long deployment period, low energy efficiency, high operation and maintenance (O&M) cost, uncertain reliability, and poor component compatibility. PowerPOD 3.0 integrates the uninterruptible power supply (UPS) and low-voltage power distribution, making the system simpler and easier to install. Compared with a traditional power supply system, PowerPOD 3.0 saves more space and power, has advantages in construction period, reliability, O&M, and total cost of ownership (TCO), and so it is widely recognized across the industry.

To better promote the PowerPOD3.0 technology, this white paper is written to provide reference for involved personnel in the industry.



CONTENTS

1. Preface	01
2. Glossary	04
3. Challenges of the Data Center Power Supply Industry	05
3.1. Large Footprint	05
3.2. Long Deployment Period	05
3.3. Low Energy Efficiency	06
3.4. High O&M Cost	06
3.5. Uncertain Reliability	07
3.6. Poor Component Compatibility	07
4. PowerPOD 3.0	08
4.1. Working Principles and Components	08
4.1.1. Working Principles	08
4.1.2. Components of PowerPOD 3.0	13
4.1.3. Typical Design Solutions	18
4.2. Installation Scenarios and Transportation	20
4.2.1. Installation Site Requirements	20
4.2.2. Transportation and Installation	20
4.3. Commissioning and Testing	21
5. Comparison Between PowerPOD 3.0 and a Traditional Power Supply System	22
5.1. Footprint Comparison	22
5.2. Deployment Period Comparison	22
5.3. Link Efficiency Comparison	23
5.4. Standardization and Substitutability Comparison	23
5.5. O&M Comparison	24
5.6. TCO Comparison	24
5.7. O&M Comparison	25

6. Fault Isolation and Reliability Analysis of PowerPOD 3.0	26
6.1. System Fault Isolation and Selective Protection Design	26
6.2. Fuse Reliability Impact Analysis	30
7. Operation and Maintenance of PowerPOD 3.0	32
7.1. Routine Inspection	32
7.2. Device Operations	33
7.3. Routine Maintenance	33
7.4. Troubleshooting	34
7.5. Emergency Operations	35
8. Summary	36

2. Glossary

Data center

A building that provides an operating environment for electronic information devices that are placed centrally. It can be one or more buildings or part of a building, and consists of a computer room, auxiliary area, support area, and administrative area.

Uninterruptible power supply (UPS)

An uninterruptible power system equipped with an energy storage device. The UPS applies to devices that require high power stability. [1]

Redundancy

Some or all components of the system are redundantly deployed. When a fault occurs in the system, the redundant components take over the work of the faulty components, thereby increasing the mean time between failures (MTBF) of the system.

Power usage effectiveness (PUE)

A parameter that indicates the power utilization efficiency of a data center. The value is the ratio of the total power consumed by all devices in a data center to the total power consumed by all electronic information devices in the data center.

Artificial intelligence (AI)

Theories, methods, techniques, and application systems used for simulating, extending, and expanding human intelligence.

Total cost of ownership (TCO)

The cost of product procurement, usage, and maintenance.

2.7. Mean time between failures (MTBF)

Average time that equipment is operating between breakdowns or stoppages.

3. Challenges of the Data Center Power Supply Industry

3.1. Large Footprint

As the computing performance of server chips keeps rising, the average power per IT rack in data centers has increased from 4 kW to 6–8 kW and will soon go up to 12–16 kW. In a traditional power supply solution, the proportion of the power room to IT space is increasing, which means a low IT rack deployment rate. Reducing the proportion of the power room to IT space has become an urgent issue in the data center industry.

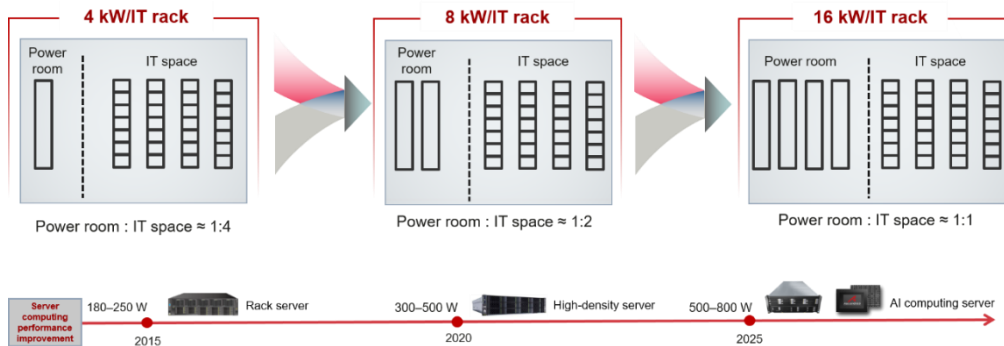

Figure 3-1 Increasing proportion of the power room to IT space in a data center

3.2. Long Deployment Period

Traditional low-voltage power supply systems generally consist of transformers, low-voltage power distribution, UPS input power distribution, UPS, UPS output power distribution, and output feeder equipment. With so many devices, the deployment period is long as construction and installation are complex.

- ① Procurement phase: Many types of devices are involved and they are from different suppliers. The procurement would take a long time as it is complex to manage the procurement bidding process and the delivery time of suppliers.
- ② Installation phase: The interface design varies with device suppliers. Onsite construction requires interconnection with different suppliers, which is inefficient and time-consuming. Devices are placed in different spaces. The electric part needs to be connected using cables or dense busways or even across different floors. Site survey is required before cable and busway preparation. The works have to be conducted one by one, demanding a heavy onsite workload and a long delivery period.
- ③ Commissioning phase: The extra low voltage (ELV) part needs to be connected to the upper-level network switch using a communications cable, and then to the power and environment monitoring system. Routing ELV cables is labor- and time-consuming. The software interface protocols of different devices are usually different. The power and environment monitoring system should support corresponding protocols, and the devices should be commissioned one by one, which requires a long period of time.

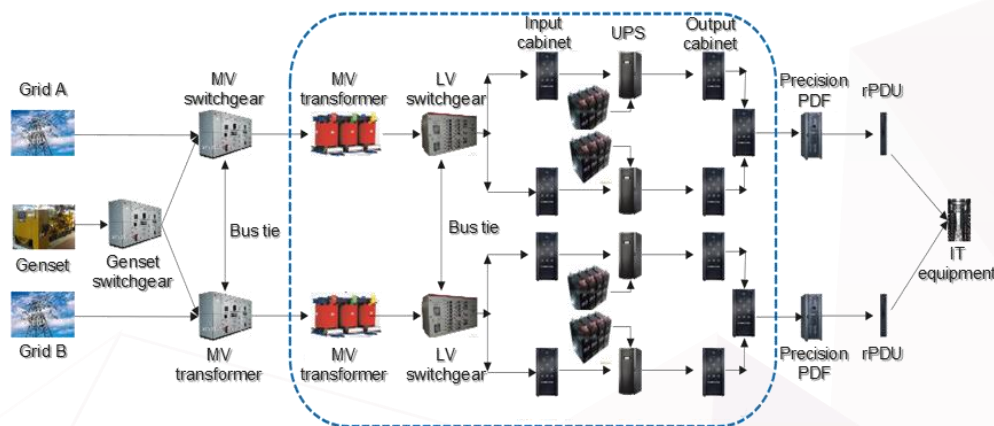

Figure 3-2 Components of the 2N power supply system for a data center

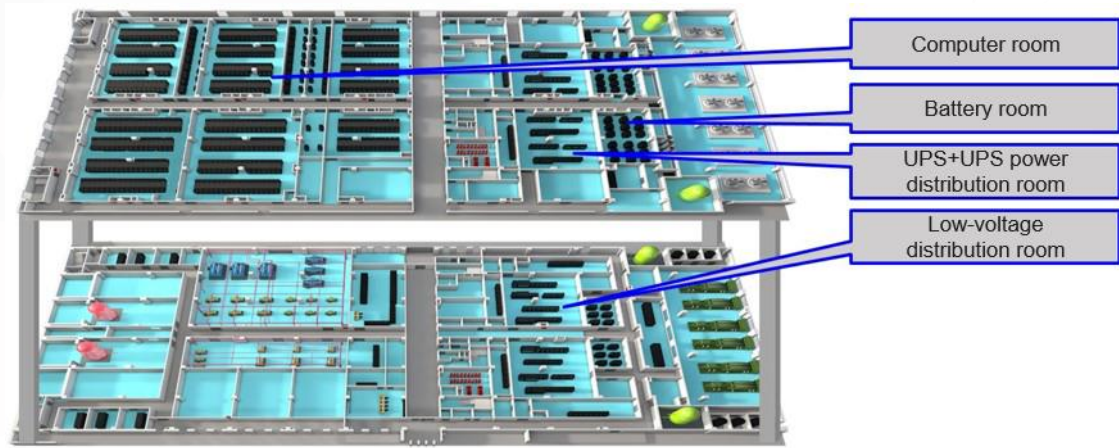
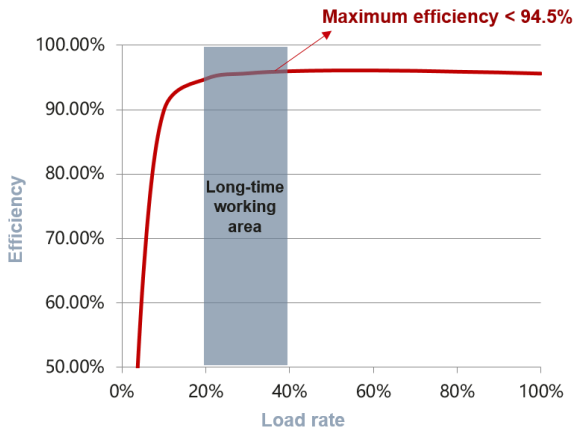

Figure 3-3 Layout of the power supply system for a data center

3.3. Low Energy Efficiency

With the continuous evolution and optimization of data center cooling systems, the typical PUE designed for data centers decreases from 1.8 to less than 1.3. The energy consumption of the power supply system rises up to about 26% of the total energy consumption of a data center. Therefore, the efficiency of the power supply system determines the upper limit of energy consumption of a data center to a large extent. An efficient and power-saving power supply system has become a must in data center construction.



Efficiency curve of the data center power supply system

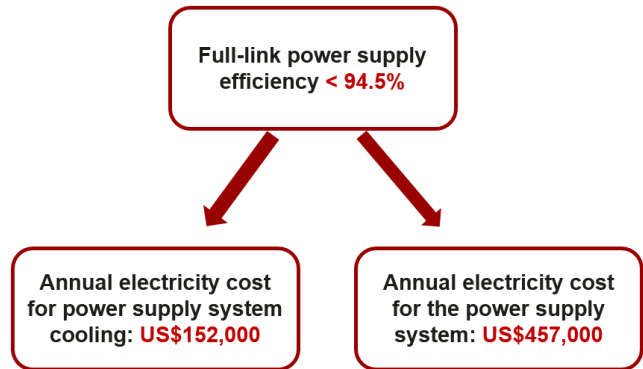

Model: 12 MW data center in Beijing, 1500 racks x 8 kW, 2N architecture, load rate 50%, air conditioner COP 3.0, electricity fee US\$0.11/kWh

Figure 3-4 Typical efficiency of the power supply system for a data center (US\$1 = CNY6.7)

3.4. High O&M Cost

O&M is a key point for attention during the lifetime of a data center. Assume that a data center houses 1500 racks and uses the traditional power supply solution, three or four O&M personnel are needed for each shift, and three shifts are required every day. A total of 9 to 12 O&M personnel are required. Routine inspection is also necessary. The O&M manpower cost accounts for about 6%–10% of the 10-year TCO of the data center. O&M efficiency should be improved to reduce the cost. Therefore, how to simplify O&M and realize O&M intelligence is also a challenge to the power supply systems of data centers.



Figure 3-5 Typical manual O&M of the power supply system for a data center

3.5. Uncertain Reliability

Each device is managed separately in a traditional power supply solution. Users are unclear about the running status of the entire power room, and can read only simple data such as voltage, current, and electric energy on the network management system (NMS). The health and safety status of the system is not directly displayed on the monitoring page. O&M personnel need to detect operation exceptions based on their technical capabilities. However, O&M personnel have unstable technical capabilities, which pose great risks to the long-term stable and reliable operation of the entire data center.

3.6. Poor Component Compatibility

A traditional power supply solution uses devices from different suppliers. The cabinet dimensions, port positions, and communication protocols vary with suppliers, making device combination and electrical connection difficult. Incompatible ports are detected only when devices are going to combined onsite, and the problem can be solved only after site survey and rectification. Different suppliers use different communication protocols. As a result, the system monitoring module should connect all devices to the upper-layer NMS, which needs to provide a separate access software package for each device. The devices run alone and do not communicate with each other. Poor compatibility makes system commissioning difficult. It is hard to locate a fault during joint commissioning.



4. PowerPOD 3.0

4.1. Working Principles and Components

4.1.1. Working Principles

4.1.1.1. Electrical System Architecture

The following compares the electrical architectures of PowerPOD 2.0 and PowerPOD 3.0 (using the PowerPOD for IT equipment with a 4 x 600 kVA x parallel system as an example).

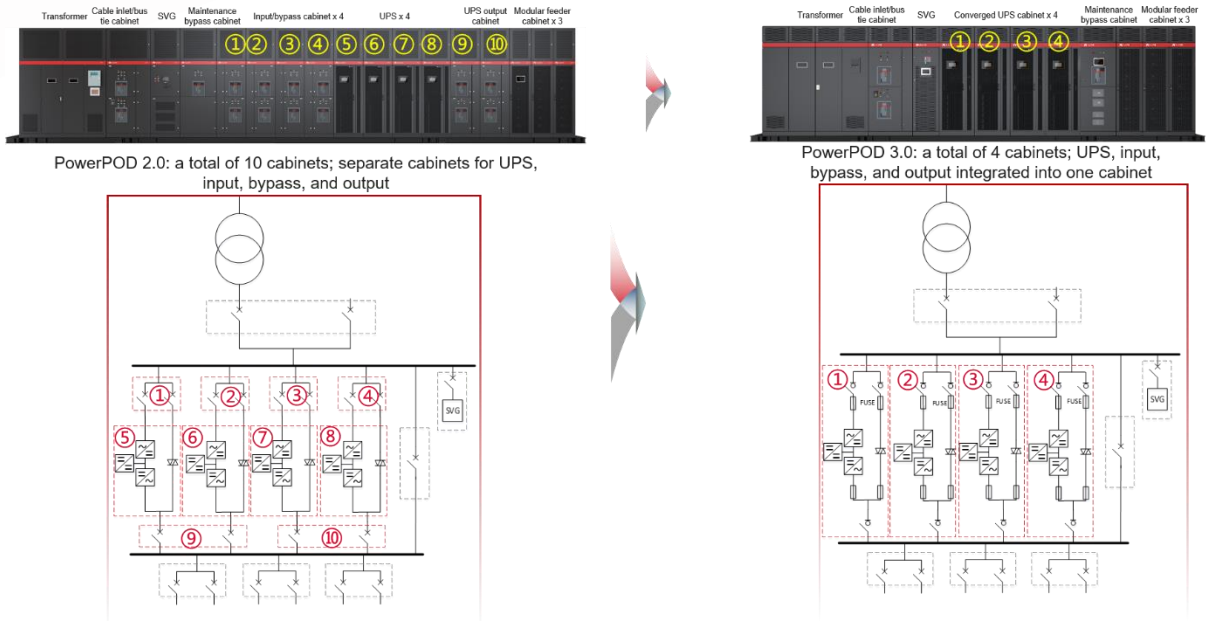
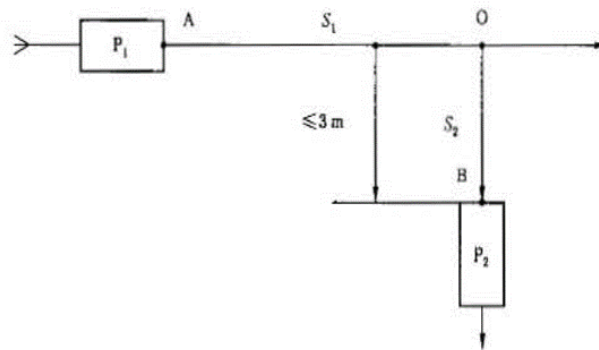

Figure 4-1 Comparison between PowerPOD electrical architectures

As required in the IEC 60364-4-43 standards, a protective device should be added within 3 m of a branch circuit.



An overload protective device (P₂) should be installed within 3 m of the origin of the branch circuit (B) (refer to 433.2.2 b).

Figure 4-2 Design requirements for protective devices in IEC 60364-4-43

The following figure shows the layout of PowerPOD 2.0. The main circuit S1 is protected by device P1 so the length of S1 is not limited. The main input copper bar on the top of the cabinets (for example, 4000 A main copper bar, as shown by blue line S1 in the right part of the following figure) of the PowerPOD is protected by the cable inlet circuit breaker (4000 A ACB, as shown by P1 in the following figure), so the length of S1 is not limited. The branch circuit S2 starts from point O to point B at branch protective device P2. S2 can have no overload or short-circuit protection (not protected by P1) and must be 3 m at most. A shown in the following figure, branch circuit S2 refers to the path (red line, conductor cross-sectional area smaller than that of the 4000 A busbar) from point O at the main copper bar on the top of the UPS input cabinet to point B at the UPS input protective device P2. S2 is not protected by the cable inlet circuit breaker (4000 A ACB, P1 in the right part of the following figure) so it must be 3 m at most.

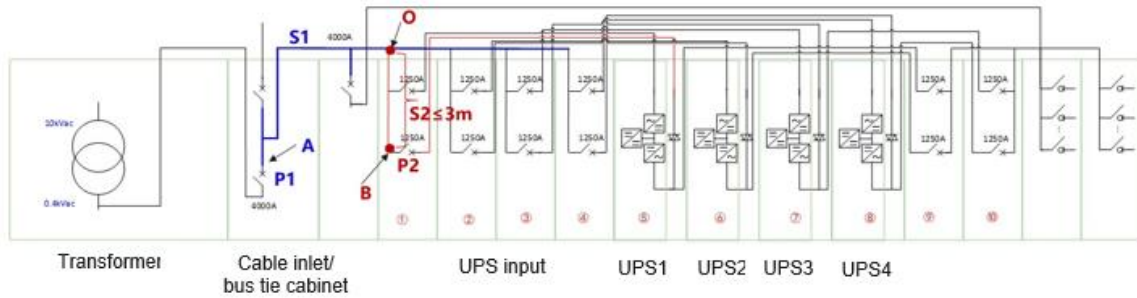

Figure 4-3 Position design of protective devices for PowerPOD 2.0

The following figure shows the layout of PowerPOD 3.0. The solution uses high-density 100 kVA UPS modules, isolation switches, and fuses to integrate the UPS and its input and output power distribution into one cabinet that features full configuration of switches and fuses 600 kVA UPS. As shown in the figure, the branch circuit S2 starts from point O to point B at the branch protective device P2. The length of S2 (red line) is no more than 3 m, which complies with the standard.

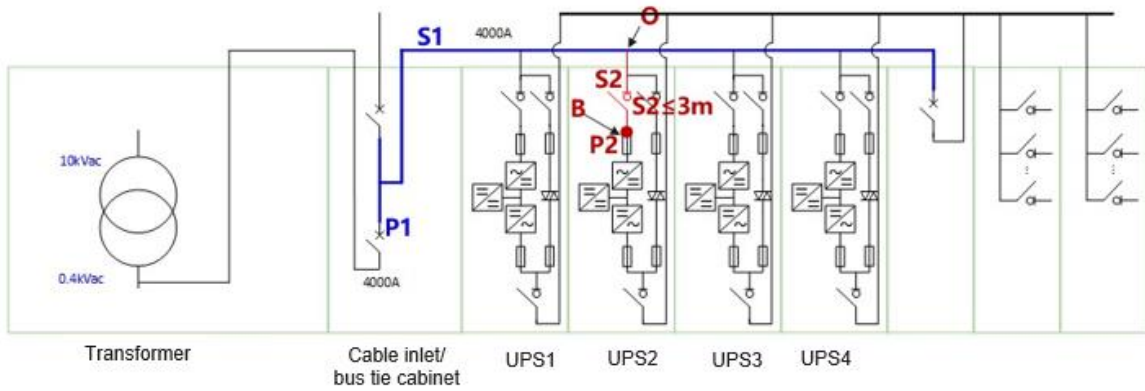

Figure 4-4 Position design of protective devices for PowerPOD 3.0

The following figure shows the electrical diagram of PowerPOD 3.0. The length of a branch from the start point to the fuse is no more than 3 m.

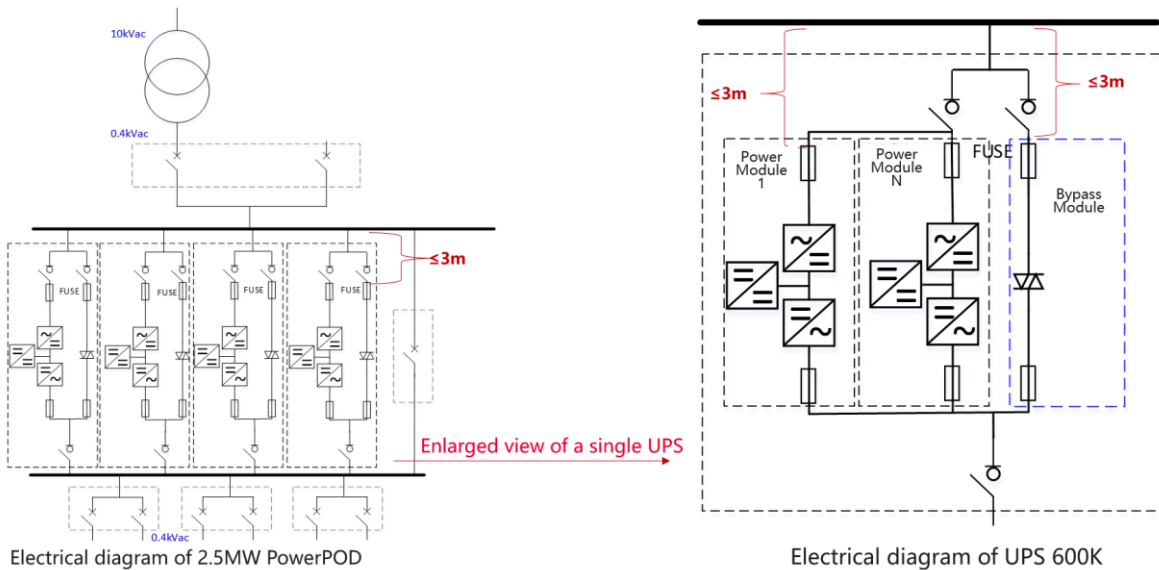

Figure 4-5 Electrical diagram of PowerPOD 3.0

4.1.1.2. Management System Architecture

The following figure shows the networking diagram of PowerPOD 3.0. The cabinet-level monitoring units of low-voltage cabinets and feeder cabinets and the controllers of the UPSs are connected to smart ETH gateways through FE ports and then to the ECC controller. The temperature controller of the transformer is connected to the ECC controller through RS485 (Modbus-RTU). The ECC controller collects the monitoring information of the entire PowerPOD and sends it to the PAD over WiFi for local display. The ECC controller provides one external communications port to connect to the NetEco over SNMP.

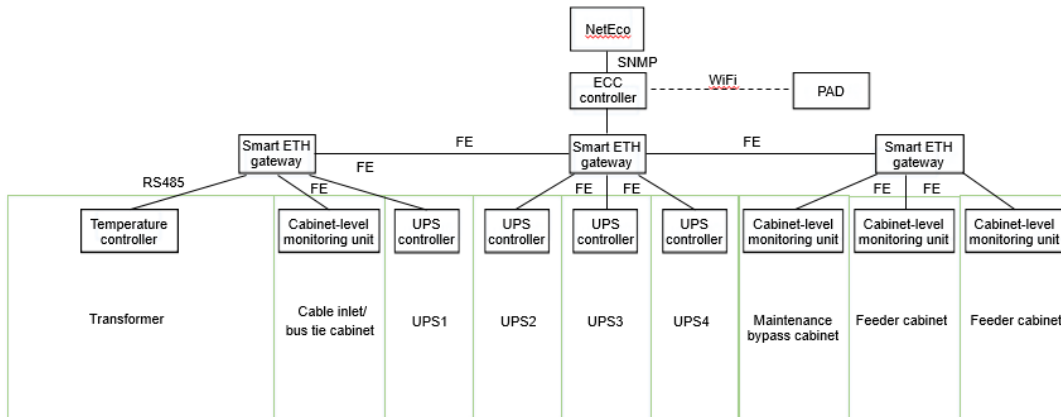

Figure 4-6 Management system architecture of PowerPOD 3.0

The NetEco is a centralized data center management platform. It seamlessly integrates data of the power supply system, building automation system, environment system, and security protection system. After obtaining the monitoring data of each subsystem in real time, the NetEco processes and analyzes the data, and determines the logic to implement centralized graphical display, monitoring, alarm reporting, data analysis, and O&M management for the subsystems. The detailed functions are as follows:

- ① Implements centralized monitoring over data center facilities, displays their running status comprehensively to accurately locate, analyze, and prevent faults, and produces statistics reports.
- ② Provides a panoramic view of the data center capacity, based on which administrators can make appropriate measures and plans.
- ③ Implements intelligent lifecycle management of data center assets and provides a unified asset management platform for enterprises.
- ④ Implements electronic data center inspection and maintenance, provides risk management, and helps O&M personnel improve O&M efficiency.



4.1.1.3. PowerPOD 3.0 Working Modes

a. Online Double-Conversion Mode

The following figure shows the key units involved in online double-conversion mode. The rectifier and inverter filter out almost all interference and harmonics in grid power, to ensure pure uninterruptible power supply to IT devices and other mission-critical devices. Harmonics caused by power devices to the power grid are also filtered out.

If grid power is abnormal, the UPS transfers to battery mode with 0 ms delay. Once grid power recovers, the UPS transfers back to normal mode with 0 ms delay. The static bypass works as the backup of the rectifier and inverter. When the inverter circuit is faulty, or the load is impacted or overloaded, the inverter stops output and the bypass is connected to directly supply grid power to loads. If the grid power quality is good, the static bypass can be used to supply power for a long period of time.

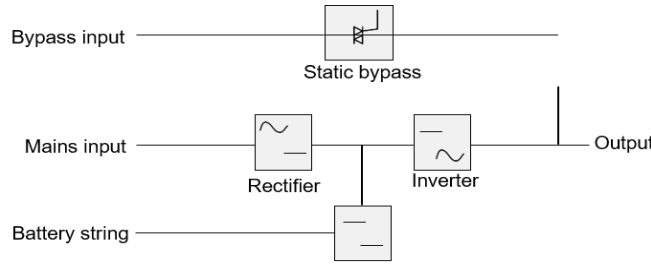

Figure 4-7 UPS electrical diagram

b. S-ECO Mode

The power supply architecture and logic are optimized in S-ECO mode to solve problems such as output interruption during power supply switching, low efficiency, and large harmonics. When the system works in S-ECO mode, the UPS automatically detects the quality of grid power supplied from the bypass. If the grid power quality is good, the UPS preferably works in bypass mode. During hot backup after the inverter is started, 0 ms transfer is implemented. When the load harmonics are greater than the preset value, the inverter compensates the harmonic component in the load. If the grid power quality is poor, the UPS works in inverter mode to ensure good power supply.

Most data center loads are dual-power servers. During normal operation, the UPS operating load ranges from 25% to 50%. The modular UPS makes full use of its flexible configuration and provides the power module hibernation function in S-ECO mode to deliver high efficiency at light load. The efficiency is higher than 98.5% at 25% load and reaches 99% at 50% load.

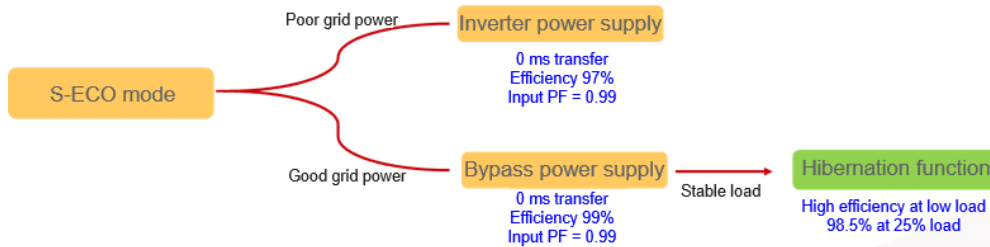
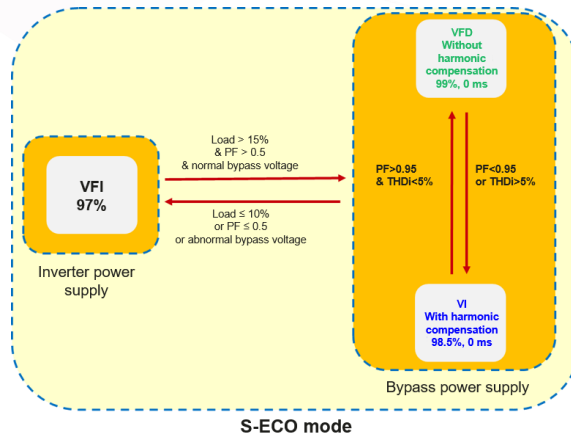

Figure 4-8 Functional diagram of Huawei S-ECO mode

Status switching principle in S-ECO mode: The bypass supplies power preferentially and automatically determines whether to compensate load harmonics based on the grid power voltage quality (V&f) and output load (PF, THDi). The following figure shows the logical diagram of switching between the three power supply states in S-ECO mode.



- Configurable bypass voltage range: ±5%, ±6%, ±7%, ±8%, ±9%, ±10%
- Configurable bypass frequency range: ±0.5, ±1.0, ±2.0, ±3.0, ±4.0, ±5.0, ±6.0
- Configurable load harmonic compensation threshold (THDi) > 5%, > 10%, > 20%, > 30%

Figure 4-9 Status switching in S-ECO mode

In S-ECO mode, when the grid power quality deteriorates or a power failure occurs, the UPS transfers to normal mode with 0 ms delay to ensure uninterrupted power supply while complying with Class 1 requirements of IEC 62040-3.

The inverter output is connected to an electronic switch in series. When the bypass supplies power, the rectifier (AC/DC) and inverter (DC/AC) keep working, and the inverter supplies the output voltage for hot backup. The inverter output voltage is cut off by the electronic switch. Although the rectifier and inverter work, they carry no loads and have low loss. All loads are directly powered by the bypass. Once the bypass input voltage becomes faulty, the power supply is switched to the mains route with 0 ms delay so the output voltage is not interrupted.

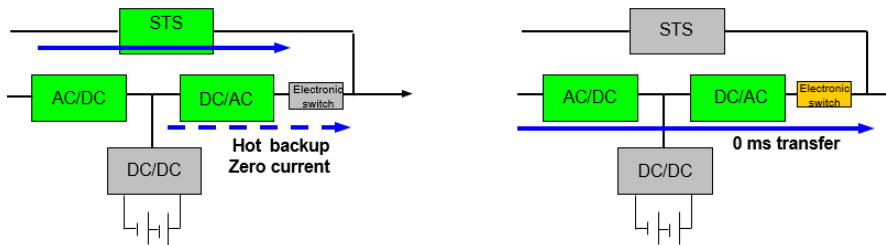

Figure 4-10 UPS operation with 0 ms transfer

In the case of input power failure, abnormal frequency or voltage, or harmonics (such as triple harmonic, trapezoidal wave, step wave, square wave, spike wave, and triangular wave) in grid power, the UPS generates an alarm indicating that the bypass voltage is abnormal and transfers to inverter mode. The output voltage is not interrupted during the transfer.

Proactive load harmonic compensation is provided in S-ECO mode. The system analyzes the UPS rack output current (I_{Load}), decomposes the harmonic component, and instructs the inverter to output a harmonic current. The inverter works in current source mode and outputs a harmonic current as instructed. The harmonic currents of loads are all supplied by the inverter. The input current (I_{bps}) is only the fundamental component, which ensures that the input current THDi from grid power is minimal.

The S-ECO mode can adapt to various combinations of loads, including RC, RL, and RCD loads. The inverter can compensate for the reactive power of the loads. The compensated reactive power can reach 100%, ensuring that the bypass input power factor (PF) is greater than 0.99 and the input THDi is less than 3%.

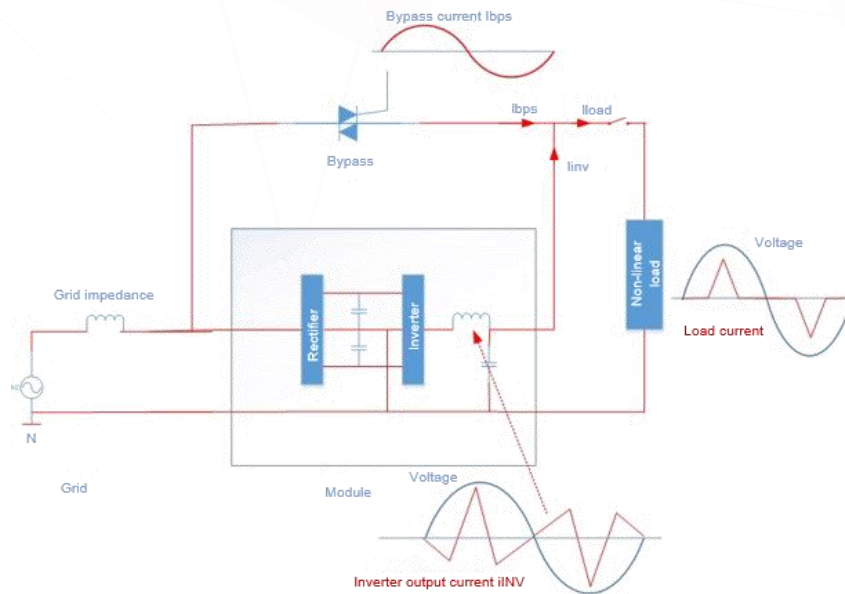

Figure 4-11 Harmonic compensation

4.1.2. Components of PowerPOD 3.0

4.1.2.2. Low-Voltage Cabinet

A low-voltage cabinet in PowerPOD 3.0 is 1.0 m deep (including the front and rear doors) and 2 m high. It is flush with the UPS, feeder cabinet, and transformer. The cabinet plus the copper bars on the top is 2.2 m high. The separation design of form 3b/4b reduces the impact of a single-point short circuit. The cabinet-level monitoring unit in the low-voltage cabinet collects the voltage, current, frequency, electric energy, harmonics, copper bar temperature, and switch status of each branch inside the cabinet.

Considering that an independent TN-S grounding system is designed for each power supply link in a data center, a 4-pole bus tie circuit breaker is recommended. Considering that the neutral-ground voltage difference should be minimal when the UPS works in battery mode, a 3-pole cable inlet circuit breaker is recommended. The breaking capacity of the cable inlet and bus tie circuit breakers must be greater than the short-circuit current of the node. Generally, the short-circuit current needs to be calculated based on the medium-voltage power grid capacity, medium-voltage link impedance, transformer capacity, and transformer short-circuit impedance. Typically, if a 2.5 MW transformer is used, the breaking capacity of the cable inlet and bus tie circuit breakers should be at least 65 kA.

As the UPS does not have a cabinet-level EMC filter board, a 3-pole circuit breaker should be used for the external maintenance bypass of the UPS. Reactive power compensation and harmonic compensation should be configured depending on project requirements. SVG is recommended for reactive power compensation and APF for harmonic compensation.

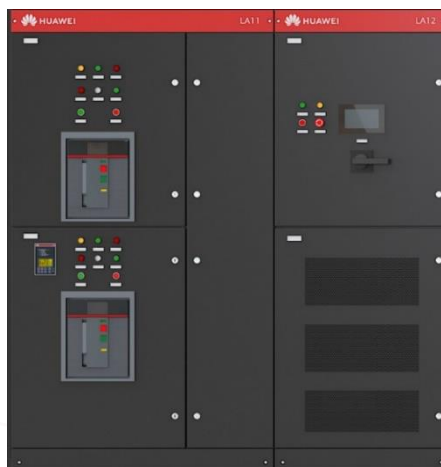

Figure 4-12 Front view of the low-voltage cabinet

4.1.2.3. UPS Cabinet

The UPS in PowerPOD 3.0 is equipped with four load isolation switches for the mains input, bypass input, internal maintenance bypass, and output. Fuses are installed for the input and output ports in the power modules for short-circuit protection. Fuses are also installed for the input and output copper bars of the bypass module for short-circuit protection. The power modules and bypass module implement overload protection through their own software.

The UPS in PowerPOD 3.0 integrates all UPS modules and four load isolation switches into one cabinet, ensuring that the conductor length of any path from a copper bar on the top of the cabinet to the fuse of a module is less than 3 m.

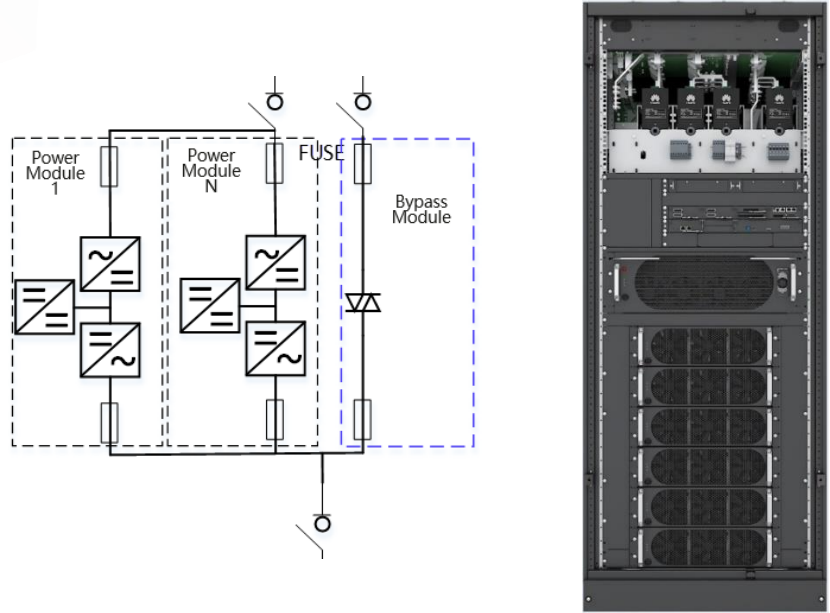

Figure 4-13 Electrical diagram and front view of the UPS

It is recommended that 400 kVA, 500 kVA, and 600 kVA UPSs be connected in parallel to meet different capacity requirements. For example, four 600 kVA UPSs can be used with a 2.5 MW transformer, four 500 kVA UPSs with a 2.0 MW transformer, or three 500 kVA UPSs with a 1.6 MW transformer to supply power to IT loads. Multiple sets of UPSs can be connected to the same transformer to supply power to different IT and power equipment.

4.1.2.4. AC Output Feeder Cabinet

The output feeder cabinet in PowerPOD 3.0 is 1.0 m deep (including the front and rear doors) and 2 m high. It is flush with the UPS, low-voltage cabinet, and transformer. The cabinet plus the copper bar on the top is 2.2 m high. The separation design of form 3b/4b reduces the impact of a single-point short circuit. The cabinet-level monitoring unit in the cabinet collects the voltage, current, frequency, electric energy, harmonics, copper bar temperature, and switch status of each branch inside the cabinet.

The 0.6 m and 0.8 m wide cabinets are designed to match different feeder output branches. The maximum current of vertical busbars is 2000 A. In a 0.6 m cabinet, a maximum of seven 400 A/630 A circuit breakers or nine 160 A/250 A circuit breakers are deployed in a single column. In a 0.8 m cabinet, a maximum of eighteen 160 A/250 A circuit breakers are deployed in two columns. The breaking capacity of a circuit breaker must be greater than the short-circuit current of the node. Generally, the short-circuit current needs to be calculated depending on the medium-voltage power grid capacity, medium-voltage link impedance, transformer capacity, transformer short-circuit impedance, upstream copper bar reactance, and the impedance of switches at each level. Typically, the breaking capacity of a circuit breaker is 50 kA.

4.1.2.5. Cabinet Connection Busbar

Cabinet connection busbars in PowerPOD 3.0 are deployed on the top of the low-voltage cabinets, UPSs, and feeder cabinets. Two layers of horizontal main busbars for input and output are designed on the top of cabinets. The lower-layer horizontal main input busbar is connected to the output of cable inlet and bus tie circuit breakers, external maintenance bypass input, and UPS input through vertical bars. The upper-layer horizontal main output busbar is connected to the UPS output, external maintenance bypass output, and feeder cabinet input through vertical bars. The horizontal main busbars are clamped at specific intervals. The short-time current tolerance capability is greater than or equal to 65 kA. The two layers of copper bars plus the top sealing plates are 475 mm high, in addition to 2 m high cabinets. The entire PowerPOD is 2.475 m high.

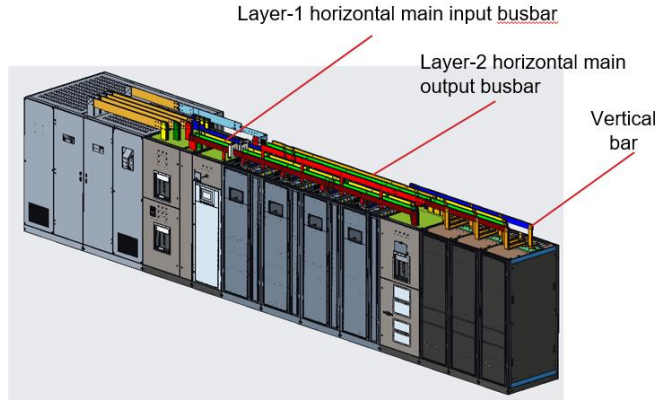

Figure 4-14 Cabinet connection busbars

4.1.2.6. Skid-mount Structure Base

If the passages for turnover and hoisting are sufficient onsite, PowerPOD 3.0 can have the transformer, low-voltage cabinet, UPS, and feeder cabinet, together with the top-mounted busbars and the monitoring system, installed on a skid-mount structure base. The whole equipment is prefabricated, assembled, and tested in the factory, and then transported to the site for installation. The base must meet the requirements regarding the load-bearing stress and vibration of transportation on level 3 roads. The base should be 150 mm high, made of 5 mm thick angle steel, and provide mounting ears for hoisting. Considering the possible adverse climate during transportation, ensure that the equipment is protected with waterproof cloth and that anti-collision and moisture-proof auxiliary materials are placed inside the equipment.



Figure 4-15 Skid-mount packing and transportation

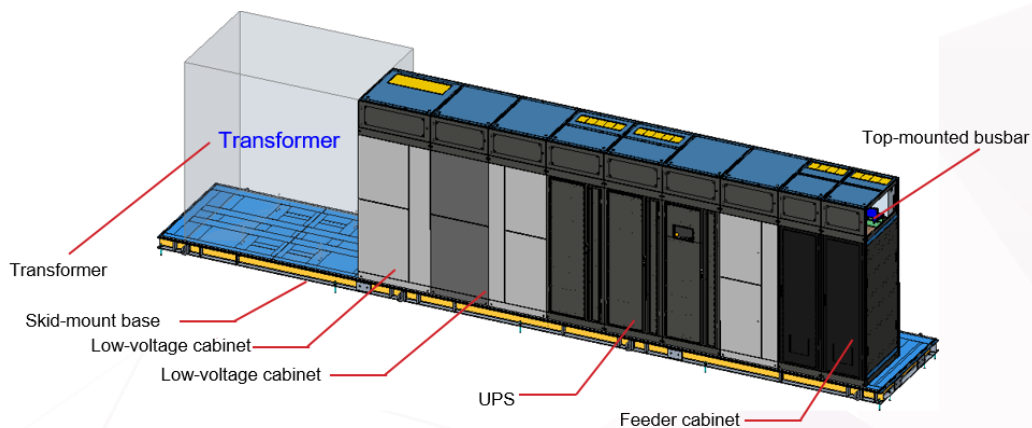

Figure 4-16 Structure with a skid-mount base

4.1.2.7. Intelligent Management System

The management system of PowerPOD 3.0 consists of a local intelligent management system and the intelligent network management system NetEco. The hardware of the local intelligent management system consists of the transformer temperature controller, cabinet-level monitoring units of the low-voltage cabinet and feeder cabinet, and UPS controller. The cabinet information is transmitted to the ECC controller through smart ETH gateways. The ECC controller centrally monitors and summarizes the data. The current, voltage, temperature, and other data of each unit in the PowerPOD are displayed on the local PAD in a unified manner. Users can easily identify the system running status. After receiving the information from the ECC, the NetEco provides intelligent O&M features such as 3D view display, running parameters (such as voltage, current, and electric energy), link diagram and fault impact analysis, online circuit breaker setting, circuit breaker health prediction, UPS capacitor and fan life detection, node temperature prediction, and AI-based exception warning, improving system O&M efficiency.

Electrical link diagram and impact analysis:

Path: **Device View > Electrical Single-Line Diagram**

Procedure: Select an electrical single-line diagram based on service requirements and click **Impact Analysis**. In the dialog box displayed on the left, select the device to be analyzed in the link diagram, for example, Q1 circuit breaker, and click **Analyze**. In this example, the mains power has failed, the bypass cannot supply power, and the battery power supply is used. The downstream power supply equipment is normal.

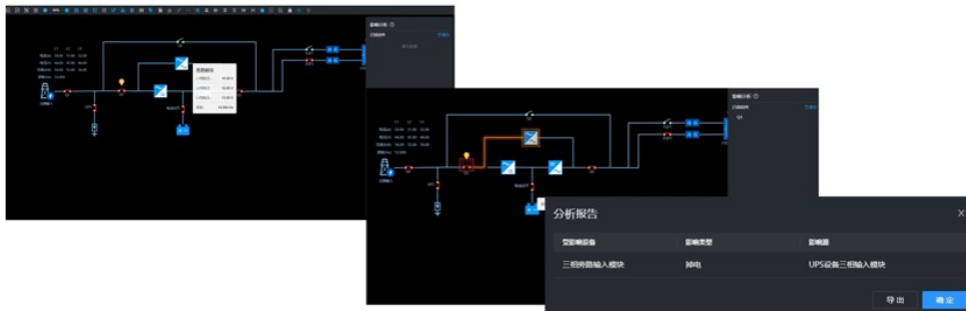

Figure 4-17 Electrical link impact analysis

Temperature detection and AI-based exception warning:

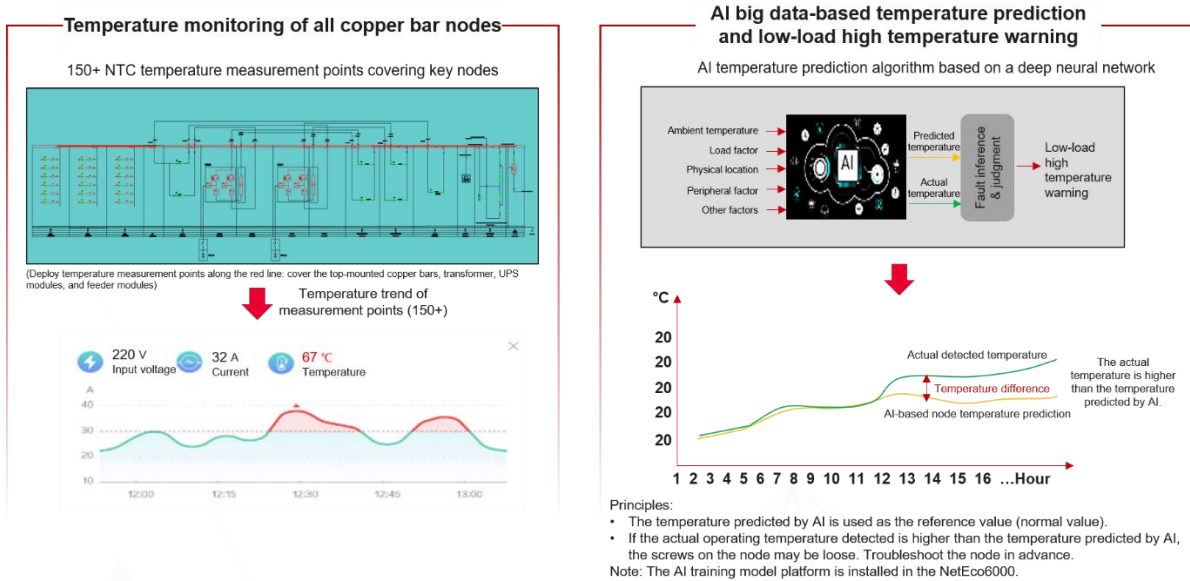

Figure 4-18 AI-based temperature warning

Online circuit breaker setting:

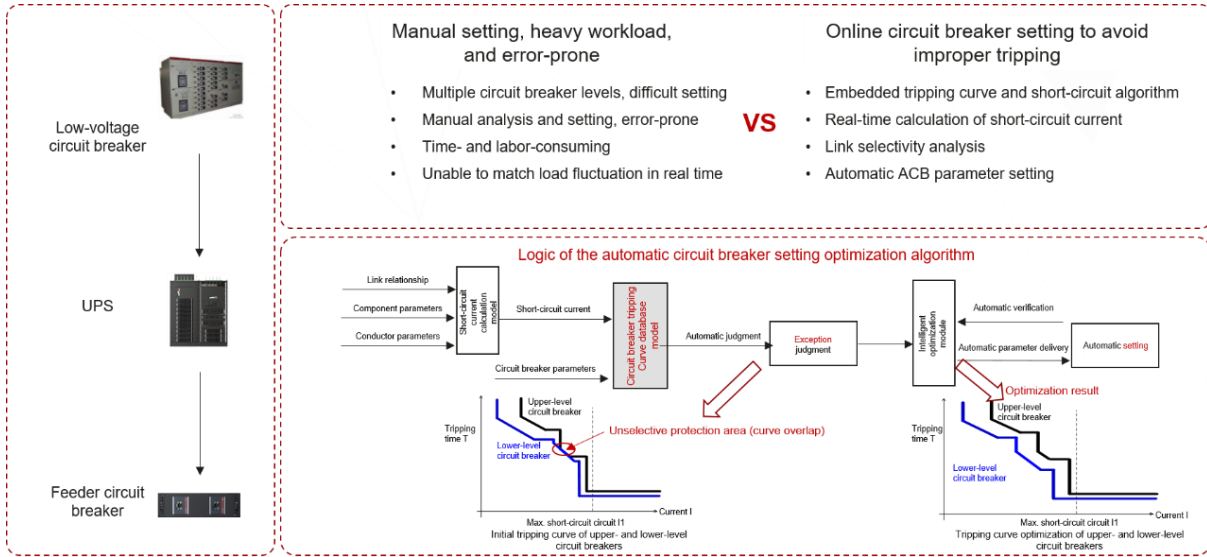
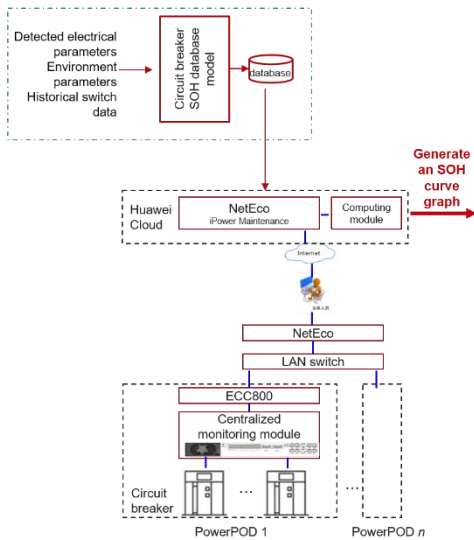

Figure 4-19 Online circuit breaker setting

Circuit breaker state of health (SOH) evaluation:

AI-based circuit breaker SOH evaluation



Details of ACB health evaluation:

- Establishes a data model library after testing the SOH of circuit breakers under different working conditions.
- Builds big database models for circuit breaker SOH.
- Embeds the database models in Huawei Cloud platform NetEco iPower Maintenance.
- Uploads PowerPOD switch data to the ECC800 through a communications module and then to the NetEco.
- Compares the measured circuit breaker data with the models in the database and identifies the model closest to the data.
- Determines the circuit breaker SOH based on the comparison result.

Figure 4-20 Circuit breaker SOH evaluation



4.1.2.8. Optional PV Module

To reduce the PUE and carbon emissions of a data center, PV modules can be deployed on the rooftop and surrounding open space of the data center. Generally, a PV module with a cross-sectional area of 1 mm² is able to yield 100–200 W power. The total power is not high. A 0.4 kV PV input can be connected on the low-voltage side. Typically, the low-voltage PV input capacity of a PowerPOD is designed as 40–200 kVA. The PV input circuit breaker can be connected to the main input busbar, and then the power will be supplied to loads through the UPS.

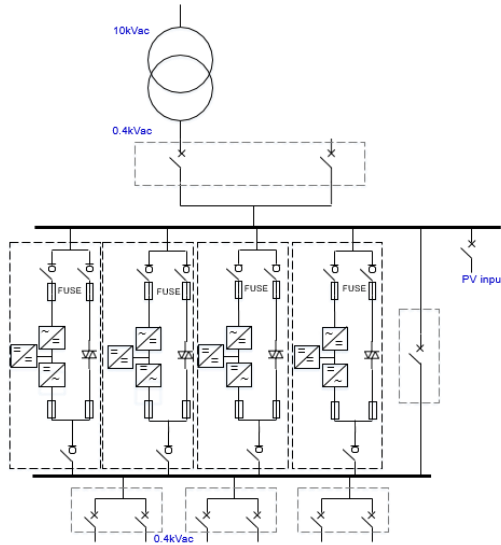

Figure 4-21 Electrical diagram of the low-voltage PV input solution for PowerPOD 3.0

4.1.3. Typical Design Solutions

The typical 2N system for a data center can be divided into two typical design solutions. Solution 1 is the PowerPOD for IT equipment. Two PowerPODs are deployed in 2N mode, a low-voltage bus tie circuit breaker is used to switch the power supply between two cable inlet circuit breakers, and the UPS output branches supply power to the same IT load. The following figure shows the electrical diagram of the system.

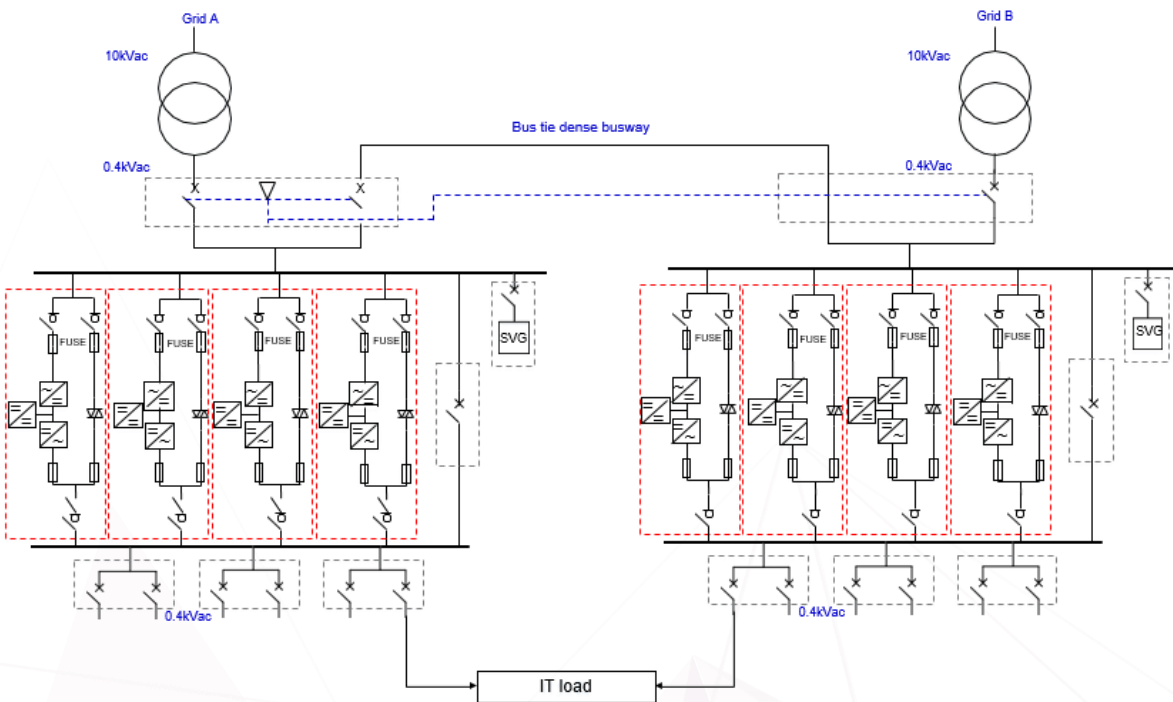

Figure 4-22 Electrical diagram of the PowerPOD for IT equipment in the 2N system

The key technical specifications are as follows.

Table 4-1 Key specifications of the PowerPOD for IT equipment

Scenario	PowerPOD for IT Equipment	
Key specifications	2.5 MW	2.0 MW
Dimensions (H x W x D)	2475 mm x 9600 mm x 1500 mm	2475 mm x 9600 mm x 1500 mm
Transformer	2500 kVA	2000 kVA
UPS	UPS5000-H-600 kVA x 4	UPS5000-H-500 kVA x 4
Feeder cabinet	250 A 3P x 9 or 400 A 3P x 7 or 630 A 3P x 7 3 cabinets	250 A 3P x 9 or 400 A 3P x 7 or 630 A 3P x 7 3 cabinets

Solution 2 is the PowerPOD for IT and power equipment. Two PowerPODs are deployed in 2N mode, and a low-voltage bus tie circuit breaker is used to switch the power supply between two cable inlet circuit breakers. The IT UPS output branches feed power to the same IT load. One power UPS and one mains supply feed power to the power load. The following figure shows the electrical diagram of the system.

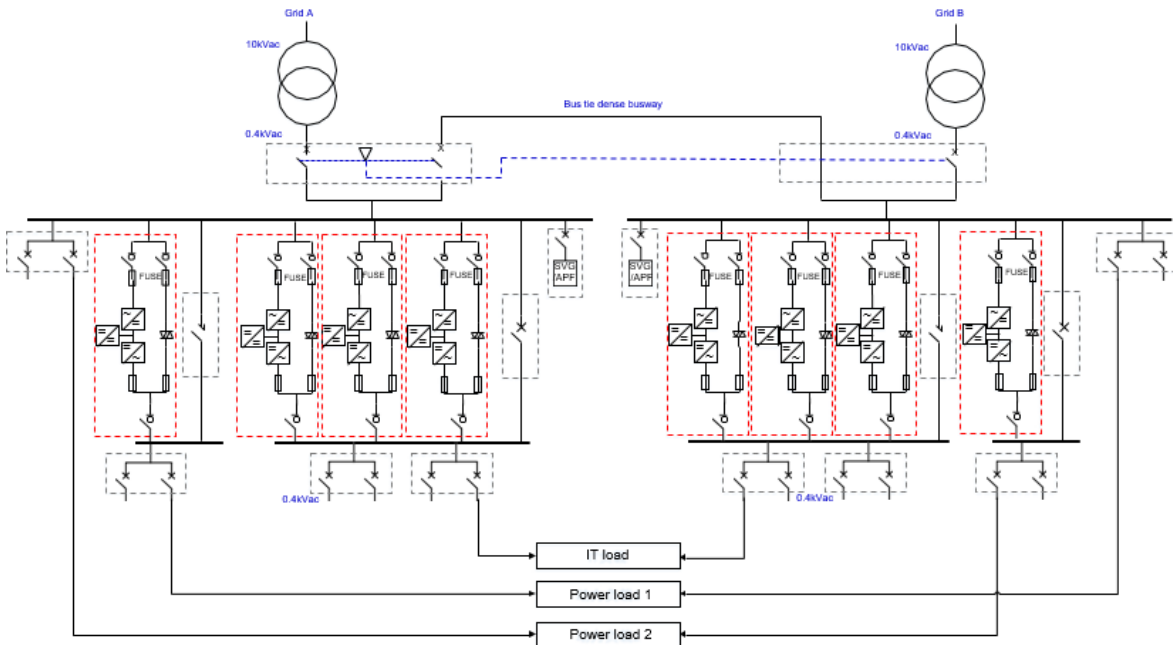

Figure 4-23 Electrical diagram of the PowerPOD for IT and power equipment in the 2N system

Table 4-2 Key specifications of the PowerPOD for IT and power equipment

Scenario	PowerPOD for IT and Power Equipment	
Key specifications	2.5 MW	2.0 MW
Dimensions(H x W x D)	2475 mm x 10,400 mm x 1500 mm	2475 mm x 10,200 mm x 1500 mm
Transformer	2500 kVA	2000 kVA
UPS	UPS5000-H-600 kVA x 3 for IT equipment UPS5000-H-500 kVA x 1 for power equipment	UPS5000-H-500 kVA x 3 for IT equipment UPS5000-H-500 kVA x 1 for power equipment
Feeder cabinet for IT equipment	250 A 3P x 9 or 400 A 3P x 7 or 630 A 3P x 7 2 cabinets	250 A 3P x 9 or 400 A 3P x 7 or 630 A 3P x 7 2 cabinets
Feeder cabinet for power equipment	250 A 3P x 9 or 400 A 3P x 7 or 630 A 3P x 7 2 cabinets	250 A 3P x 9 or 400 A 3P x 7 or 630 A 3P x 7 2 cabinets

4.2. Installation Scenarios and Transportation

4.2.1. Installation Site Requirements

The installation site for PowerPOD 3.0 should meet the following requirements:

- ① If the space is not limited, reserve at least 2300 mm in front of the PowerPOD, at least 1000 mm at the rear, and at least 800 mm on the top.
- ② If the space is limited, reserve at least 2100 mm in front of the PowerPOD, at least 800 mm at the rear, and at least 500 mm on the top.
- ③ When the transformer side is used as the main transportation passage, the minimum clearance is 1500 mm. When the feeder cabinet side is used as the O&M passage, the minimum clearance is 800 mm.
- ④ When the feeder cabinet side is used as the main transportation passage, the minimum clearance is 1500 mm. When the transformer side is used as the O&M passage, the minimum clearance is 800 mm.
- ⑤ The PowerPOD installation site should be able to bear the concentrated load of at least 1.8 T/m². The requirements on the distributed load of the room should be calculated based on the specific design of a project.

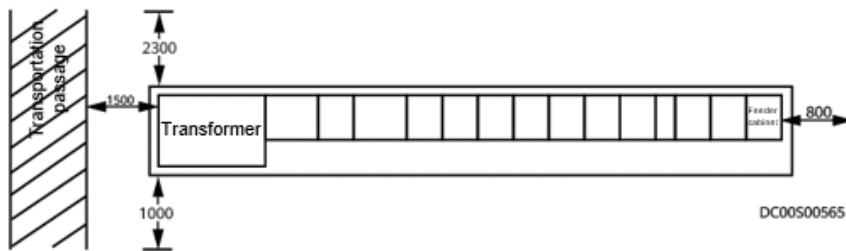

Figure 4-24 Site requirements (the transformer side is used as the transportation passage in this example, unit: mm)

4.2.2. Transportation and Installation

PowerPOD 3.0 may involve two transportation scenarios. In scenario 1, each cabinet is delivered to the site and secured to the cabinet mounting holes on the channel steel base due to limited site conditions. In scenario 2, the cabinets are skid-mounted (prefabricated) for transportation and installation. The preparations in scenario 2 are as follows:

- ① Hoist the skid-mounted (prefabricated) PowerPOD 3.0 onto a trailer and transport it to the site.

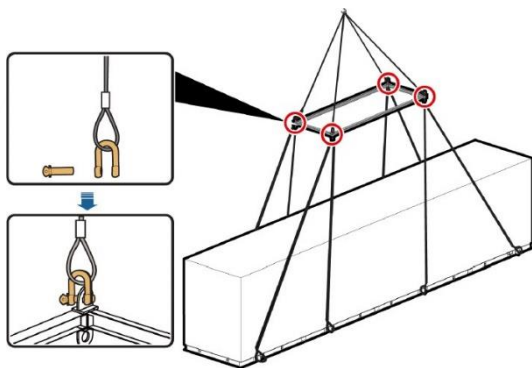
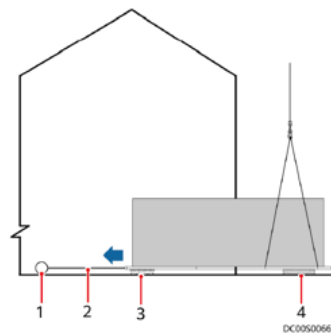

Figure 4-25 Skid-mount hoisting



(1) Winch (2) Traction sling (3) Moving dolly

Figure 4-26 Skid-mount placement

- ② Determine the installation position and direction of the PowerPOD based on the site space, and ensure that the installation floor is flat.
- ③ During unloading, use a crane to hoist one end of the PowerPOD into the room and land the PowerPOD onto the moving dolly at the entrance of the unloading area. Use an electric winch to slowly push the PowerPOD into the room with the moving dolly under the rear part, and secure the PowerPOD in place.

4.3. Commissioning and Testing

PowerPOD 3.0 should be commissioned in the following sequence of power supply: transformer -> cable inlet and bus tie cabinet -> maintenance bypass cabinet -> feeder cabinet. If PowerPOD 3.0 is skid-mounted, it has been tested and only needs to be powered on after delivered to the site. After the commissioning is complete, commission each UPS and then the parallel system. Finally, switch off the maintenance bypass cabinet and complete the power-on commissioning of the power supply system. Connect a PC to the ECC, log in to the ECC, configure it, and test the monitoring system.



5. Comparison Between PowerPOD 3.0 and a Traditional Power Supply System

5.1. Footprint Comparison

PowerPOD 3.0 integrates the high-density UPS5000-H and UPS input and output power distribution. Compared with the traditional solution, the number of cabinets is reduced from 22 to 11 for a 2.5 MW PowerPOD, cutting the footprint by 40%. In the model with 1500 racks, 8 kW/rack, and 2N architecture, if the footprint of an IT rack is 3 m², 170 more IT racks can be deployed.

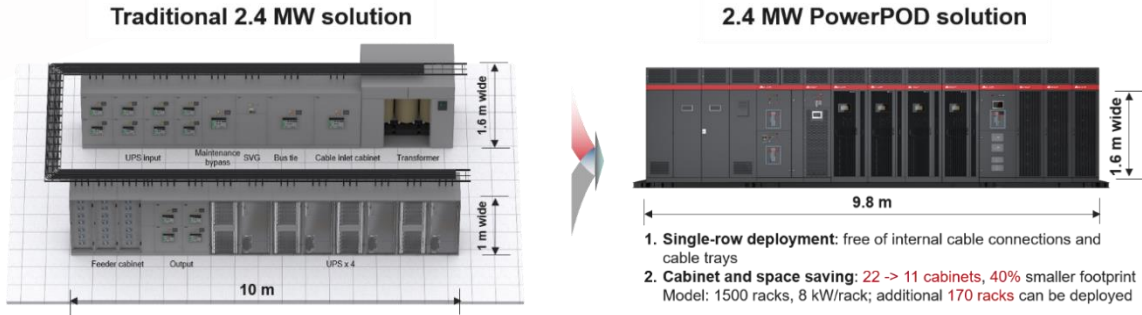

Figure 5-1 Footprint comparison

Table 5-1 Calculation of additional racks supported in PowerPOD 3.0

Item	Traditional Solution Footprint	PowerPOD 3.0 Footprint	Space Saving	Additional IT Racks Supported
Calculated value	1266 m ²	756 m ²	510 m ²	170

5.2. Deployment Period Comparison

In the traditional solution, 15 copper bars and 264 cables need to be connected onsite for a 2.5 MW PowerPOD. Devices are provided by multiple suppliers. Copper bars and cables need to be prepared after site survey. Other necessary work includes device installation, bus cable processing and installation, device commissioning, joint commissioning, and system verification. The deployment period exceeds two months. PowerPOD 3.0 is preinstalled and commissioned before delivery. Users only need to install it and connect it to the upper-layer NMS onsite for joint commissioning.

The deployment period is less than two weeks. If cabinets are delivered separately, the cabinets and copper bars need to be installed onsite. In that case, the deployment period is about two weeks.

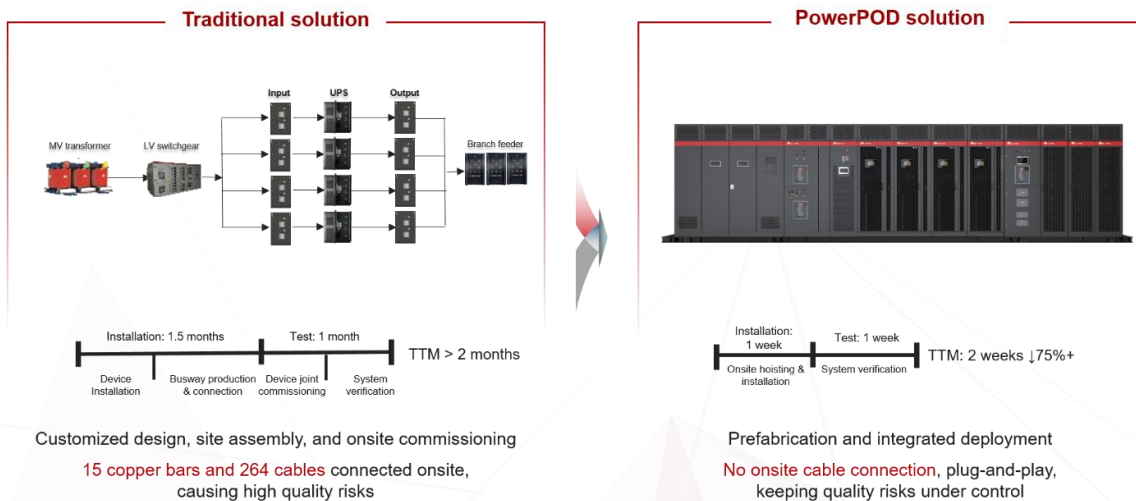

Figure 5-2 Deployment period comparison

5.3. Link Efficiency Comparison

PowerPOD 3.0 uses the high-efficiency UPS-5000-H plus converged links to improve the efficiency. Compared with the traditional solution, the efficiency of the UPS working in double conversion mode is raised from 94.5% to 95.6%, an increase of 1.1%. If the UPS works in S-ECO mode, the efficiency will be as high as 97.8%, an increase of 3.3%.

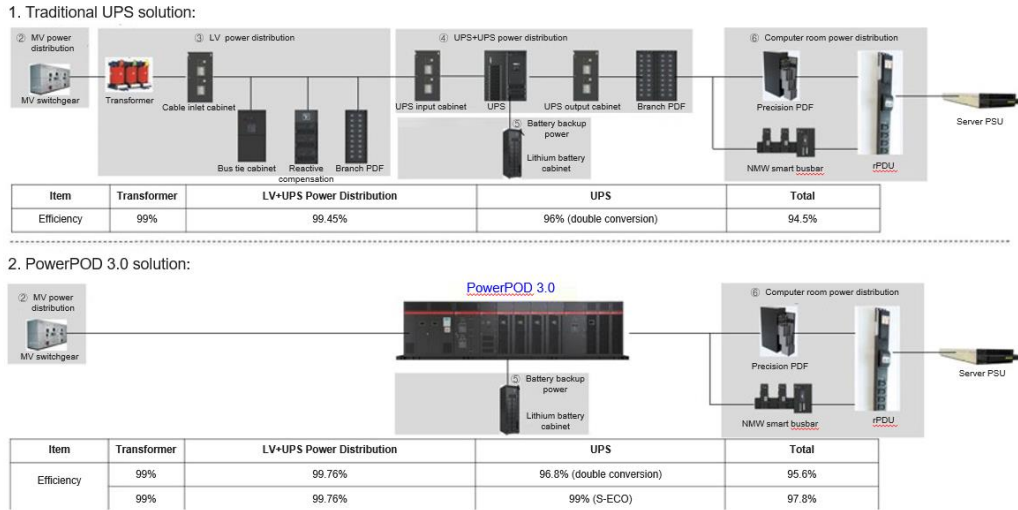

Figure 5-3 Link efficiency comparison

5.4. Standardization and Substitutability Comparison

PowerPOD 3.0 is an integrated product that can be replicated in batches in a standardized manner, simplifying design, delivery, acceptance, and O&M. Thanks to modular design, any of key components in PowerPOD 3.0 such as the UPS power module, bypass module, power distribution feeder module, SVG/APF module, monitoring module, and centralized controller can be replaced within 5 minutes.

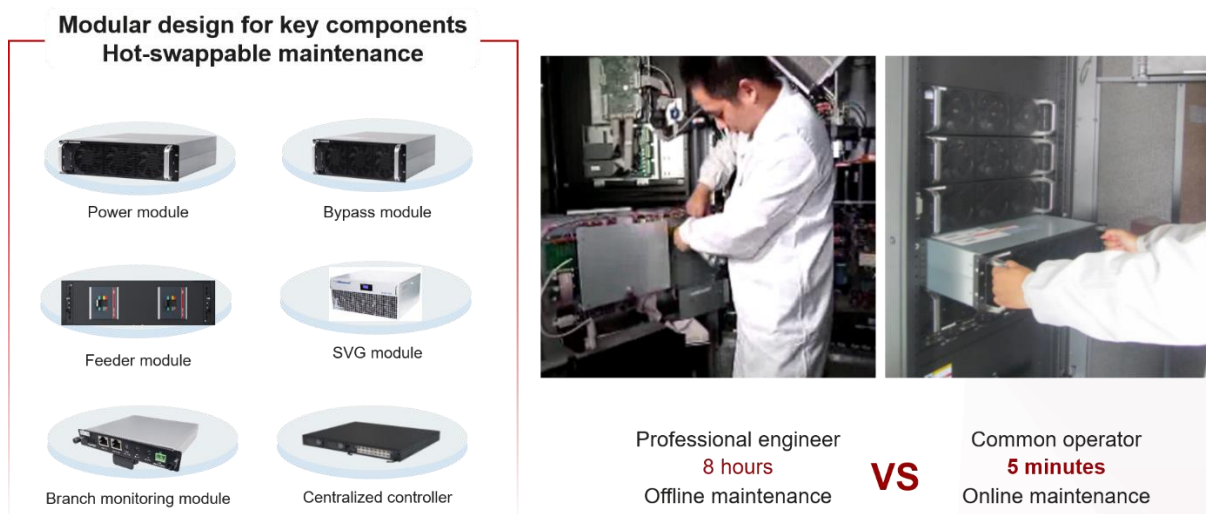

Figure 5-4 Modular design of key components for hot swapping

5.5. O&M Comparison

PowerPOD 3.0 monitors and manages all links in an efficient, visualized, and centralized manner, and uses AI technologies to implement intelligent and reliable O&M. Compared with the traditional solution, PowerPOD 3.0 features enhanced O&M efficiency and predictable O&M to ensure secure and controllable operations.

Table 5-2 O&M comparison

Item	Traditional Solution	PowerPOD 3.0
Display on the management system	Each switch component is separately metered and managed. The local display does not show the system running status.	The information about all links is displayed on the PAD. Users can view the running status of each link in the system.
Predictable O&M	Not supported. Only periodic inspection and passive maintenance are provided. Operation safety risks are uncontrollable.	The following technologies are used to implement predictable O&M: Copper bar temperature measurement and AI warning Circuit breaker health evaluation Circuit breaker setting to prevent improper tripping

5.6. TCO Comparison

5.6.1. CAPEX Comparison

The CAPEX of a data center includes the costs of construction, devices, installation, and commissioning. The building construction cost is affected by the footprint of the power supply system. Compared with the traditional solution, PowerPOD 3.0 features high density and occupies 40% less footprint. Using a 12 MW data center with 1500 racks as an example, PowerPOD 3.0 leaves space for deploying 170 more racks, about 10% higher than that in the traditional solution.

The installation and commissioning costs are closely related to the complexity of system composition. Compared with the traditional solution that uses devices from multiple suppliers, PowerPOD 3.0 has natural advantages in installation and commissioning. For the same configuration, the installation and commissioning period is shortened from two months to two weeks, with the costs reduced by over 50%.

PowerPOD 3.0 is a highly integrated product with strict requirements on design and production, leading to higher costs per cabinet than the traditional solution though fewer cabinets are used. Using a 12 MW data center with 1500 racks as an example, the CAPEX of PowerPOD 3.0 is equivalent to that of the traditional solution.

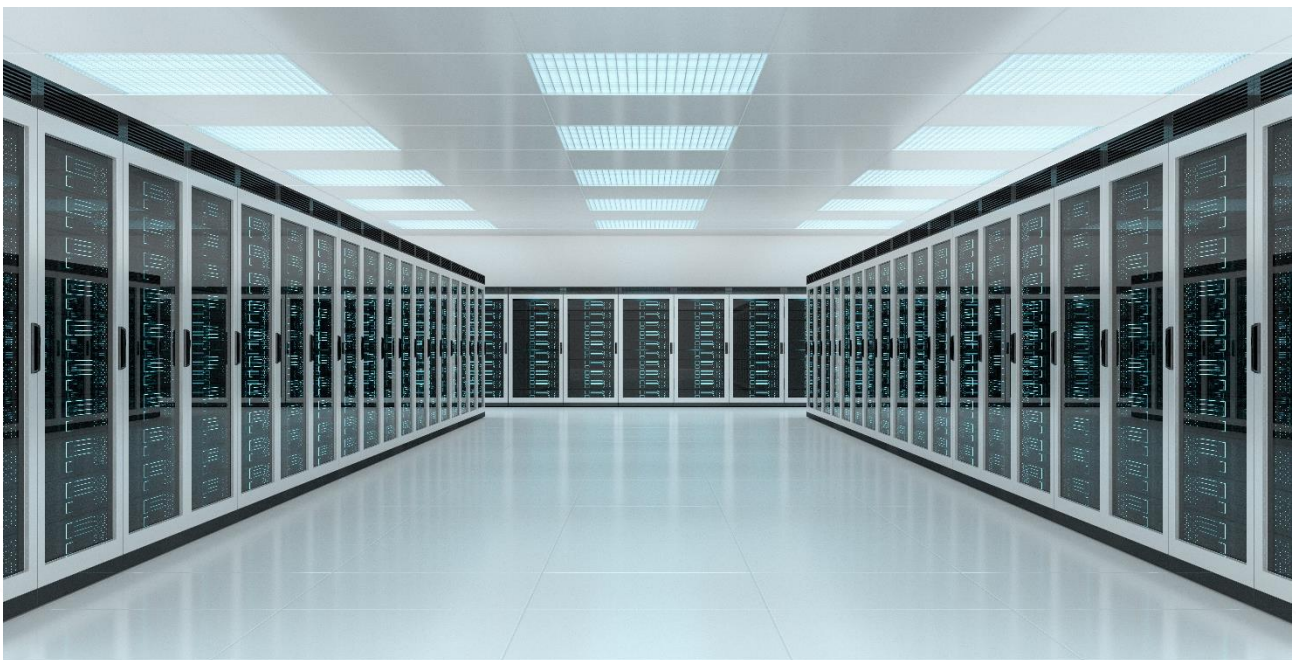

5.6.2. OPEX Comparison

The OPEX of a data center includes the costs of electricity, water, consumables, and routine maintenance. The electricity cost depends on the PUE of the data center. The routine maintenance cost depends on the system complexity.

Compared with the traditional solution, PowerPOD 3.0 delivers 1.1% higher efficiency in double conversion mode and 3.3% higher efficiency in S-ECO mode, optimizing the PUE of the entire data center. Use a 12 MW data center with 1500 racks, 50% load rate, and US\$0.11/kWh electricity fee as an example. The data center has a 10-year life cycle. Compared with the traditional solution, PowerPOD 3.0 reduces the 10-year electricity cost by about US\$0.96 million in double conversion mode and about US\$1.9 million in S-ECO mode.

The traditional solution uses devices from multiple suppliers, causing complex O&M. The devices and parameters to be inspected are several times those of PowerPOD 3.0. During the lifetime of the data center, the traditional solution requires higher O&M costs than PowerPOD 3.0.

Use a XX data center as an example. The data center has 1500 racks and a power density of 8 kW/rack. The local electricity fee is US\$0.11/kWh, and the load rate is 50%. The 10-year OPEX is estimated as follows.

Table 5-3 TCO comparison between PowerPOD 3.0 and the traditional power supply system for a data center

XX Data Center	Unit	Traditional Solution	PowerPOD 3.0
Rated IT capacity	kW	12,000	12,000
Power room construction cost	US\$10,000	A	0.6A
Cost of power supply devices	US\$10,000	B	B
Installation cost	US\$10,000	C	0.5C
Electricity cost for cable loss	US\$10,000	D	0.82D (double conversion) 0.4D (S-ECO)
O&M cost (including labor and spare parts)	US\$10,000	F	0.8F
TCO (10 years)	US\$10,000	G	0.9G (double conversion) 0.74G (S-ECO)

5.7. O&M Comparison

PowerPOD 3.0 integrates the UPS input and output power distribution. Compared with the PowerPOD 2.0, the power supply system is simpler and ensures a lower failure probability because it has fewer connection points. In addition, the skid-mount solution is prefabricated and tested in the factory using standard procedures and is less likely to introduce failure points, so it is more reliable than the PowerPOD 2.0. The following table compares the two 2.5 MW solutions in theoretical MTBF and system downtime (min/year).

Table 5-4 Reliability comparison

Item	PowerPOD 2.0	PowerPOD 3.0
MTBF (hrs)	137608.43	154043.77
System downtime (min/year)	1.93	1.92



6. Fault Isolation and Reliability Analysis of PowerPOD 3.0

6.1. System Fault Isolation and Selective Protection Design

Working condition 1: If the feeder output port of a branch in the PowerPOD is short-circuited, PowerPOD 3.0 triggers the same protection as the traditional solution or PowerPOD 2.0. The circuit breaker of the faulty branch is disconnected for isolation, and the other branches work as usual, as shown in the following figure.

If an output port of the PowerPOD is short-circuited, the feeder circuit breaker of the branch trips and the faulty branch is isolated.

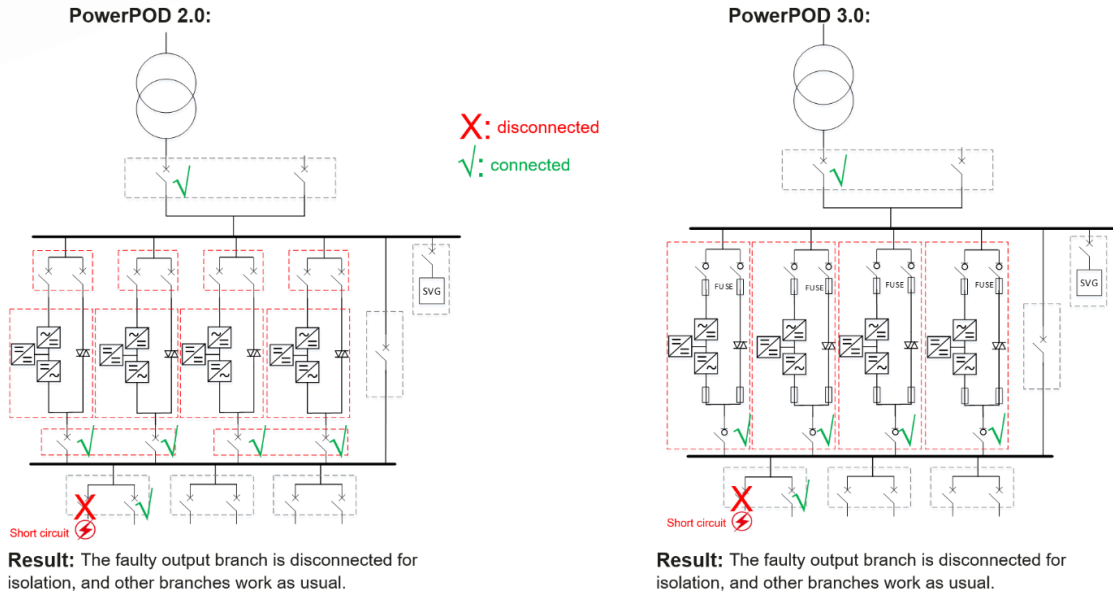

Figure 6-1 Analysis on the impact of branch output short-circuit

The following figure shows the selective protection curves of a feeder branch MCCB and UPS fuse. The MCCB is a 630 A thermomagnetic (non-adjustable magnetic) circuit breaker that represents the worst working condition for selective protection. As shown in the figure, the UPS fuse (1800 A) and the MCCB (630 A) meet the time-selective protection requirements. If the 630 A MCCB output is short-circuited, the fuse will not blow for protection. MCCBs with a capacity of 630 A or less can provide time-selective protection with UPS fuses.

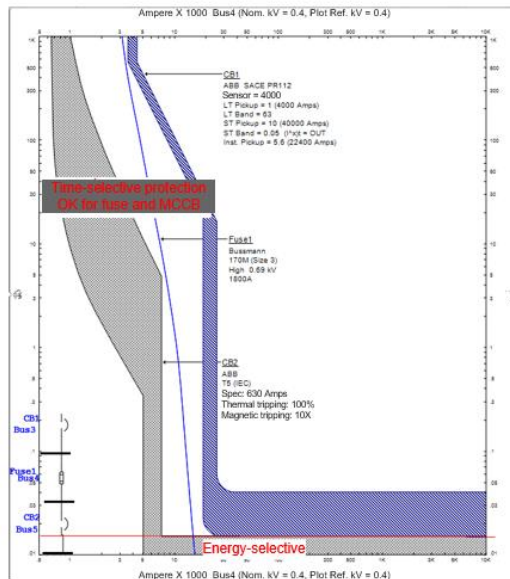

Figure 6-2 Selective protection curves of a fuse and its downstream circuit breaker

Working condition 2: If a UPS bypass module is faulty, PowerPOD 3.0 has a smaller range of protective isolation than the traditional solution or PowerPOD 2.0. Only the faulty bypass is disconnected, and other routes work as usual, as shown in the following figure.

If a UPS bypass module of the PowerPOD is faulty, only the faulty bypass stops working, other modules work as usual, and the fault isolation range is smaller.

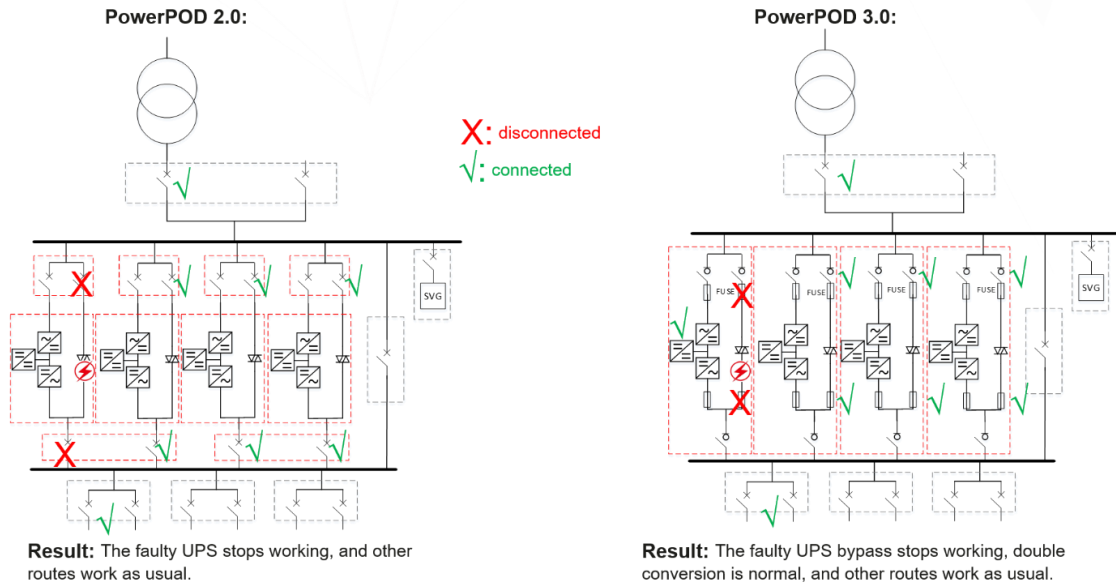

Figure 6-3 Analysis on the impact of UPS bypass module short-circuit

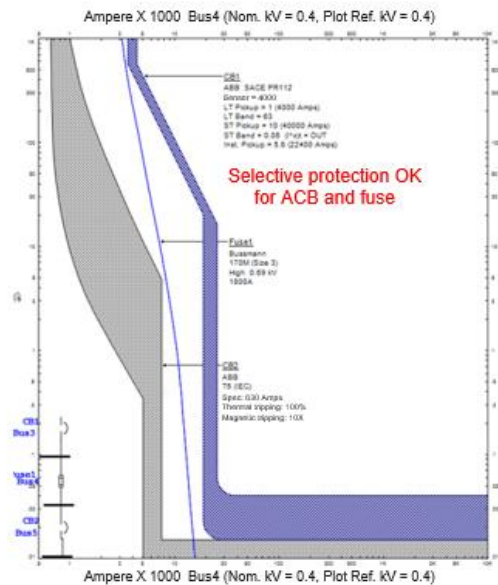

Figure 6-4 Selective protection curves of a fuse and its upstream circuit breaker

As shown in the preceding figure, the 4000 A ACB and fuse implement selective protection for the whole range of time.

Working condition 3: If a UPS power module is faulty, PowerPOD 3.0 has the same range of protective isolation as the traditional solution or PowerPOD 2.0. Only the faulty power module is disconnected, and other routes work as usual, as shown in the following figure.

If a power module of the PowerPOD is faulty, only the faulty module stops working and others work as usual.

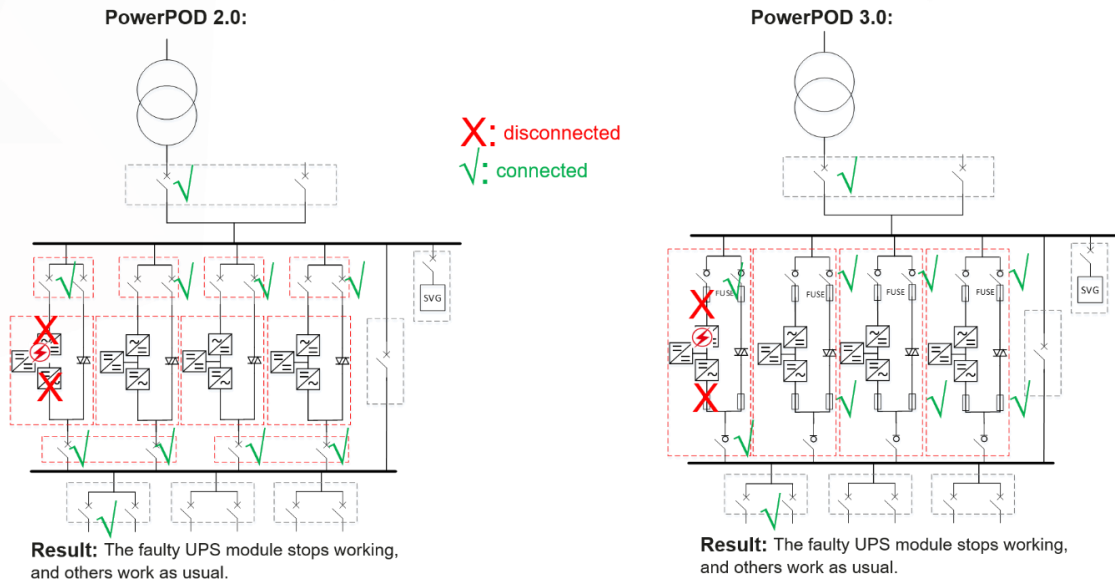

Figure 6-5 Analysis on the impact of UPS power module short-circuit

Working condition 4: If a bus of the PowerPOD is short-circuited, both solutions stop working and the 2N system ensures uninterrupted power supply to IT loads in the data center, as shown in the following figure.

If the output bus of the PowerPOD is faulty, the entire PowerPOD stops working.

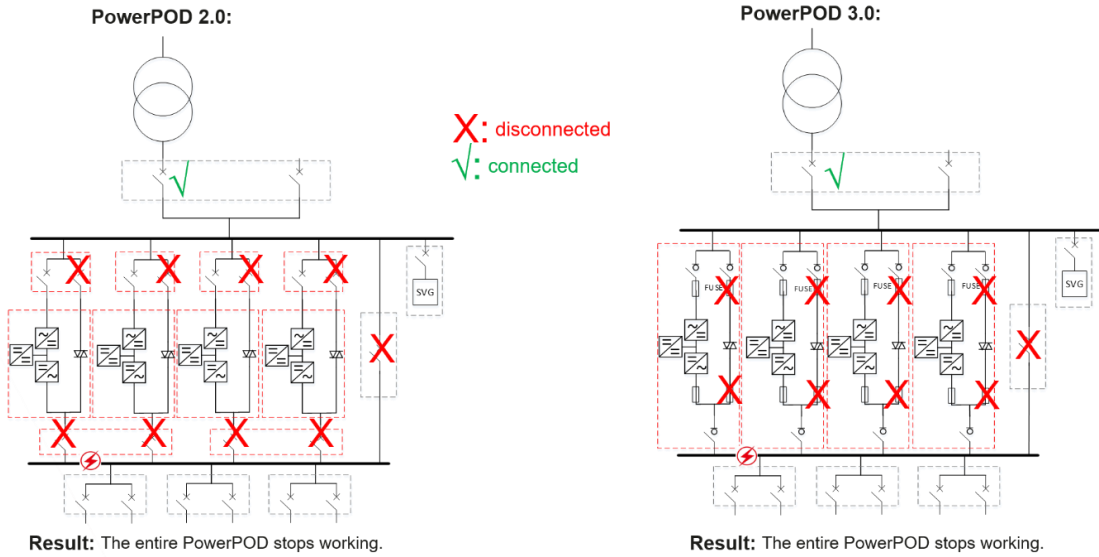

Figure 6-6 Analysis on the impact of UPS output bus short-circuit

If the input bus of the PowerPOD is faulty, the entire PowerPOD stops working.

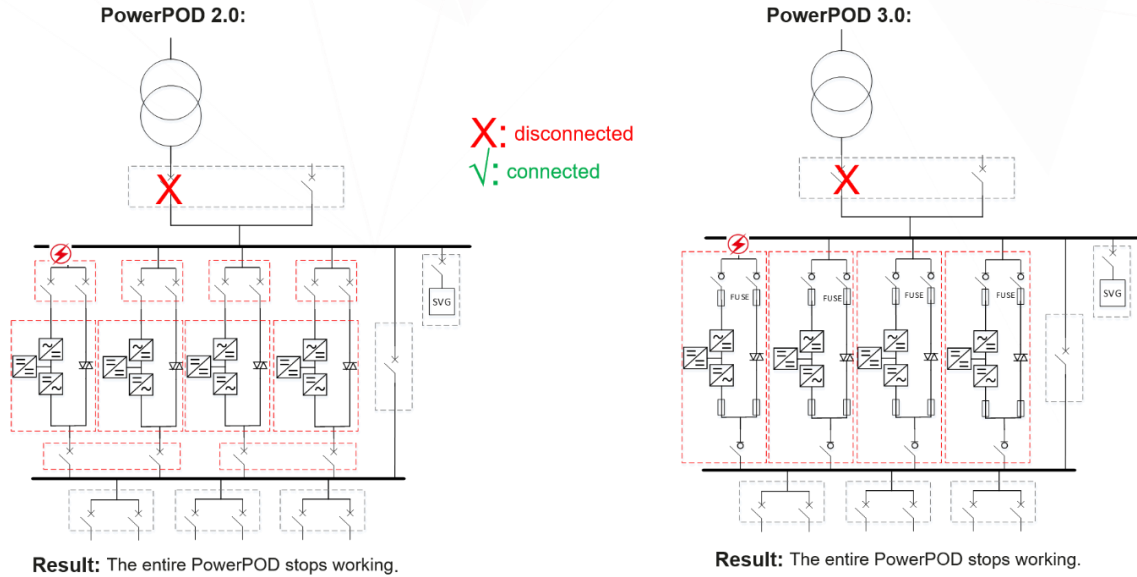

Figure 6-7 Analysis on the impact of UPS input bus short-circuit

Working condition 5: If a short circuit occurs between the UPS input switch and a UPS power module, PowerPOD 3.0 stops working and the 2N system ensures uninterrupted power supply to IT loads in the data center. Compared with the traditional solution or PowerPOD 2.0, PowerPOD 3.0 has a larger theoretical fault scope but lower probability of short circuit since it no longer uses a separate UPS input cabinet. The system reliability is basically the same, as shown in the following figure.

If the UPS input switch of the PowerPOD is short-circuited to a UPS power module. The entire PowerPOD 3.0 stops working, but the probability is very low.

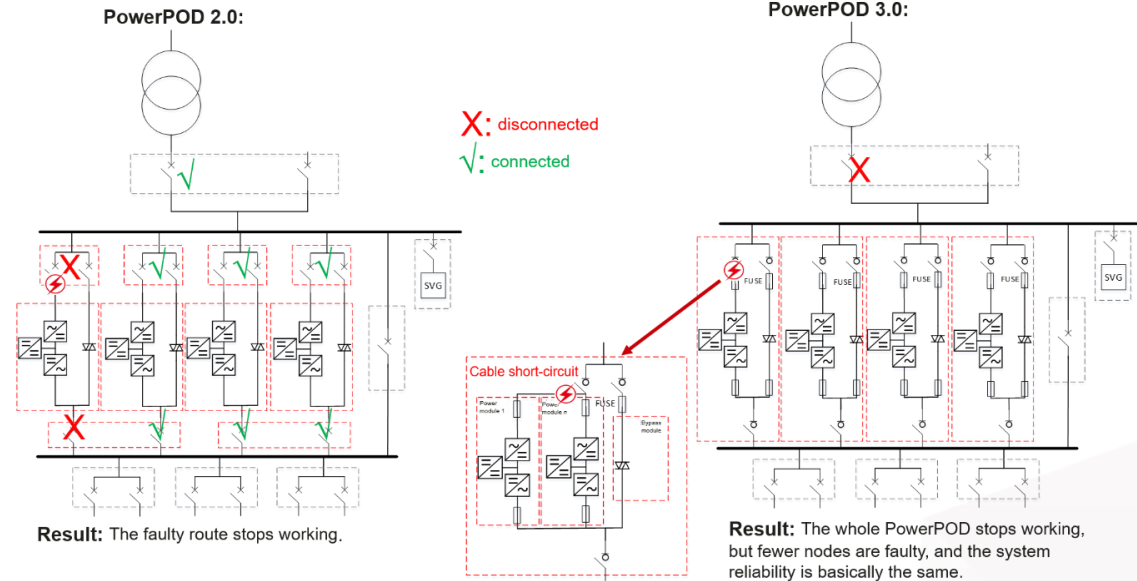

Figure 6-8 Analysis on the impact of UPS cabinet cable damage and short-circuit under extreme working conditions

6.2. Fuse Reliability Impact Analysis

The capability of fuses to bear the pulse current varies with working conditions, such as the pulse frequency and time. The following table lists the claimed pulse current bearing capability of fuses under different conditions.

Table 6-1 Fuse capability to bear pulse current

Frequency of occurrence	Overloads (>1 sec)	Impulse loads (<1 sec)
Less than one time per month	$I_{max} < 80\% \times I_t$	$I_{max} < 70\% \times I_t$
Less than twice per week	$I_{max} < 70\% \times I_t$	$I_{max} < 60\% \times I_t$
Several times a day	$I_{max} < 60\% \times I_t$	$I_{max} < 50\% \times I_t$

The following figure shows the I_t curves of fuses that vary with the pulse time.

Table 6-2 Fuse I_t curves

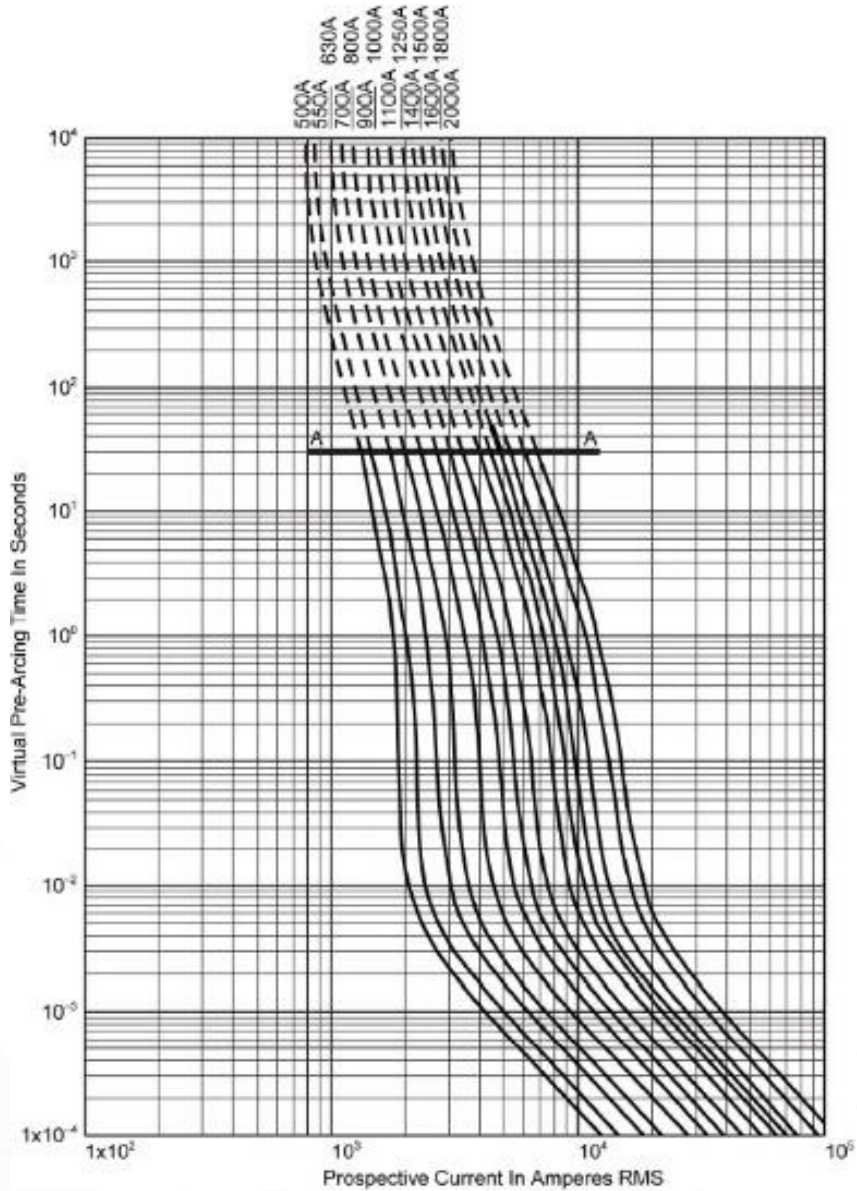

Working condition 1: impact analysis under IT load conditions

Considering that the working conditions of a data center may be complex, the IT load impulse current is evaluated with the assumption that all server power supply units (PSUs) restart for three to five times every day and that the pulse time is 1s though it is less than 1s.

$$I_{max} \leq I_t \times 50\% = 10500 \times 0.5 = 5250$$

I_{max} indicates the maximum pulse current of 5250 A/1s, which is a multiple of the 600 kVA full-load current.

$$\text{Multiple} = I_{max} / [600 \times 1000 \text{ W} \times 1.05 \text{ (charge coefficient)} \times 0.9 \text{ (load coefficient)} \times 1.2 \text{ (voltage fluctuation coefficient)} / 220 \text{ V} / 3 / 0.96 \text{ (efficiency)}] = 5.01$$

According to the industry specifications, the impulse current of server PSUs must be less than 1.5 times the full-load current and below 5.01. Therefore, the impulse current is far less than the pulse current that fuses can bear. There is no risk even if the fuse capability tolerance is 10%.

Working condition 2: impact analysis under typical power load conditions

Power devices with high load power include chillers, cooling towers, and fans. The fans and cooling tower pumps account for a small proportion of power while the chiller compressors account for the largest proportion. The compressors can be variable- or constant-frequency. Variable-frequency compressors have a smooth impulse current, basically the same as the full-load current. There is no risk of using them in data centers involving green and energy saving metrics.

Constant-frequency compressors are used in scenarios that focus on CAPEX investment. Compressors of large chillers are deployed using an architecture of N+1, which is 2+1 at least. For example, in the 4+1 architecture, five compressors are started one by one. The startup pulse current of each compressor is 5 to 7 times the full-load current and the pulse time is less than 10s (take 10s). The impulse current that the fuses can bear is calculated as follows:

$$I_{max} \leq I_t \times 60\% = 7300 \times 0.6 = 4380 \text{ A}$$

I_{max} indicates the maximum pulse current of 4380 A/10s, which is a multiple of the 600 kVA full-load current.

$$\text{Multiple} = I_{max} / [600 \times 1000 \text{ W} \times 1.05 \text{ (charge coefficient)} \times 0.9 \text{ (load coefficient)} \times 1.2 \text{ (voltage fluctuation coefficient)} / 220 \text{ V} / 3 / 0.99 \text{ (efficiency)}] = 4.31$$

According to the preceding analysis, if compressors are deployed using the typical 4+1 architecture, when the last of the five compressors is started, the pulse current reaches the maximum value, which is 2.2 times ($1/5 \times 7 + 4/5 = 2.2$) the full-load current and less than 4.31. Therefore, there is no risk. In the worst working condition where compressors are deployed using the 2+1 architecture, the pulse current is three times the full-load current ($1/3 \times 7 + 2/3 = 3$) and less than 4.31. Even if the fuse capability tolerance is 10%, there is no risk ($3 < 4.31 \times 0.9$).

To sum up, the pulse current generated by typical IT and power loads in data centers is less than the value that the fuses can bear. Therefore, the fuse life will not be shortened by excessive pulse current and there is no risk in system operation.



7. Operation and Maintenance of PowerPOD 3.0

7.1. Routine Inspection

Table 7-1 Routine inspection checklist (example)

Category	Check Item	Expected Result	Troubleshooting
Environment	Operating environment	Ambient temperature: 0–40°C Humidity: 0%–95% RH (non-condensing) Rodent-proof measures have been taken for the equipment room. The equipment room is airtight.	If the temperature or humidity is abnormal, check the air conditioner status. Install a rat guard at the door of the equipment room. Check that the equipment room is airtight and not in a direct ventilation environment.
	Power grid environment	Input voltage of the low-voltage cable inlet and bus tie circuit breakers: 380 V AC/400 V AC/415 V AC (line voltage) ±10% Input frequency: 50 Hz	If the input voltage is abnormal, check the power grid status and input cable connection. If the input frequency is abnormal, check the medium-voltage power grid frequency.
System	Display	The status icons on the PAD app indicate that all units are operating properly, all operating parameters are within their normal ranges, and no fault or alarm information is displayed.	If an alarm is present, rectify the fault by checking the device status and parameters.
UPS	Output voltage	Output voltage: 380 V AC/400 V AC/415 V AC ±1% (line voltage)	If the output voltage is abnormal, check the UPS running status and check whether an alarm is generated.
	Display	The status icons on the LCD indicate that all units are operating properly, all operating parameters are within their normal ranges, and no fault or alarm information is displayed.	If an alarm is present, rectify the fault by checking the device status and parameters.
	Air filter	The air filter is not blocked.	Clean up dust from the heat dissipation channel.
SVG	Device	No abnormal noise is generated.	Clean the dust on the fan.
	Air filter	The air filter is not blocked.	Clean up dust from the heat dissipation channel.
Transformer	Check the noise generated during device running.	The fan generates no abnormal noise.	Check that the fastener is secured. Check the running status and ensure that the temperature does not exceed the specifications specified in the nameplate.
	Enclosure	No abnormal noise is generated from other components. There is no obvious collision or looseness on the enclosure.	If abnormal noise is generated during operation, refer to the transformer troubleshooting instructions or contact technical support. If the enclosure is abnormal, repair it in a timely manner.
Low-voltage cabinet	Circuit breaker	The cable inlet, bus tie, and maintenance bypass circuit breakers (ACBs) are in the correct positions (ON/OFF).	If the cable inlet circuit breaker is OFF and the bus tie circuit breaker is ON, check whether the controller triggers switching due to abnormal medium-voltage input. If the maintenance bypass circuit breaker is ON, check whether it is operated by mistake.
Feeder cabinet	Circuit breaker	The branch circuit breakers connected to loads are ON.	If a circuit breaker trips, check for exceptions such as overload and downstream short-circuit.

7.2. Device Operations

- ① Running status check: Log in to the PAD app. The home screen displays the link diagram and cabinet view. You can tap each cabinet image to go to the details screen and view the running parameters. The alarm screen displays the alarm information of the PowerPOD, including active and historical alarms. The active alarms screen displays the device alarms that have not been handled. The alarms are classified into four levels by severity. When a new alarm is generated, it is displayed on the top of the list. You can filter alarms by generation time, clearance time, and severity. You can select the tick icon to acknowledge an alarm or the x icon to delete the alarm. You can tap **Details** to view the alarm details and the solution. The historical alarms screen displays the old alarms which can be sorted by alarm severity and time.
- ② UPS operation settings: UPS operation parameters, such as S-ECO and online double-conversion modes, can be set on the UPS LCD based on the operation requirements of the actual O&M plan.
- ③ Bus tie circuit breaker operation settings: Bus tie circuit breaker control parameters such as switching delay, threshold, and automatic or manual mode can be set on the controller LCD of the cable inlet and bus tie cabinet based on system requirements.

7.3. Routine Maintenance

Table 7-2 Routine maintenance checklist (example)

Category	Check Item	Expected Result	Troubleshooting
UPS	Cleanliness	When the cabinet surface is wiped using white paper, the paper does not turn black.	Remove the dust, especially from the air filter on the front door, or replace the air filter.
	Parameter settings	The settings of the output voltage level, frequency, number of batteries, and battery capacity meet requirements.	Reset the parameters.
	Status record	Record the three-phase load rate and output power factor.	If an exception occurs, check the load status.
	Shallow discharge test (recommended)	Conduct a shallow discharge test when the UPS is backed up to verify that the batteries can discharge normally.	If an alarm is generated, refer to the alarm list.
	Grounding	Ground cables are connected securely.	Tighten the bolts.
	Power cable and terminal	The insulation layers of cables are intact and terminals are free from black marks and noticeable sparks.	Replace the cables. Secure all output terminals.
	Through-current capacity of cables and switches	Switches and cables meet load requirements. The actual through-current capacity of cables is greater than the switch specifications.	Replace the switches. Replace the cables.
	Air filter	The air filter is not blocked.	Clean up dust from the heat dissipation channel.
Transformer	Fan	No abnormal noise is generated.	Clean the dust on the fan.
	Resin insulation of windings	The resin insulation of windings does not crack.	If there is a tiny crack on the resin insulation of windings, confirm it with the manufacturer. Ensure that the transformer operates within the specifications specified in the nameplate.
	Coil	The coil surface is clean. No discharge occurs along the coil surface and the pad surface.	Promptly cut off the power supply and clean up the dust on the coil. If continuous discharge occurs on the transformer coil and pad, shut down the device and clean up the dust immediately.
	Power-on indication and safe locking system	The power-on indication is displayed normally. The power supply is automatically switched off if the transformer cabinet door is opened.	If the power-on indication and the safe locking system are abnormal, power off the device and troubleshoot it.
Power distribution cabinet	Copper bar connection	The copper bar bolts are tightened and marked with red and blue lines. The washers are properly crimped. The copper bar connections are free from black marks and noticeable sparks.	Use a torque wrench to check that bolts are tightened. If sparks have occurred, clean and replace the damaged component.
	Switch	The color of switches is normal. The switches can be turned on and off properly. No abnormality is found in manual trip testing.	Replace the abnormal switches.

7.4. Troubleshooting

The common alarm handling process is as follows.

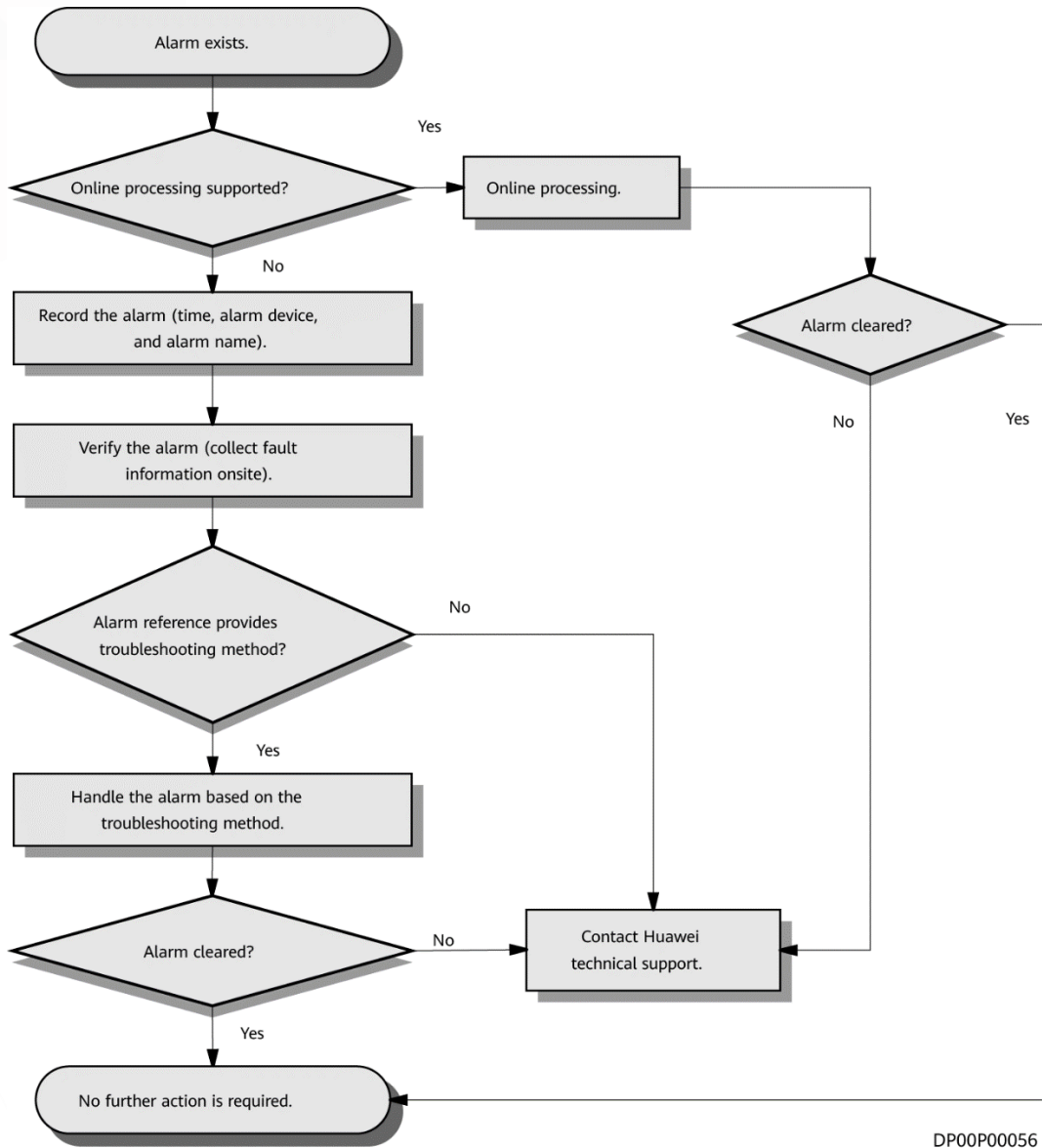

Figure 7-1 Common alarm handling solution

Common parts replacement policy: The UPS power module, bypass module, power distribution feeder module, SVG/APF module, monitoring module, and ECC centralized control module can be hot-swapped for replacement. ACBs can be drawn out for replacement. Transformer fans are located in the medium-voltage area and can be replaced only after the medium-voltage supply is disconnected.

7.5. Emergency Operations

In the case of an emergency that affects the normal operation of the entire system, perform the operations as follows:

- ① If a UPS is faulty, check the load rate of other normal UPSs. If the load rate is less than 100%, no action is required. If the load rate is less than 125%, the UPS automatically transfers to bypass mode. If the load rate is greater than 125%, manually turn on the external maintenance bypass switch to use the mains power supply.
- ② If a bus is short-circuited and the cable inlet circuit breaker of a PowerPOD trips, quickly locate the short-circuit point and observe the severity of damage. If only the short-circuit point is slightly damaged and the fault is rectified, clean the involved area to ensure that no short circuit will occur, and then turn on the circuit breaker to power on the PowerPOD.
- ③ If a transformer is faulty, for example, due to overtemperature or abnormal vibration, turn off the cable inlet circuit breaker of the involved route and turn on the bus tie circuit breaker to use the other route of transformer output to power the loads. After the transformer fault is rectified, manually switch the power supply back to the transformer.



8. Summary

PowerPOD 3.0 integrates input and output power distribution with the UPS that delivers high density and efficiency. Compared with the traditional solution, PowerPOD 3.0 reduces the footprint by 40%, improves the efficiency by 1.1% in UPS dual-conversion mode and by 3.3% in the UPS S-ECO mode, and shortens the delivery period by 7% thanks to the prefabricated integration technology.

In addition, full-link visualized centralized management and AI-based intelligent O&M features improve O&M efficiency and operation reliability while reducing costs. The PowerPOD 3.0 technology offers an effective solution to reduce carbon emissions, improve efficiency, and drive green development of data centers. In the future, more innovative technologies such as energy mix optimization, PV deployment, and energy storage can be used to further reduce energy consumption and carbon emissions throughout the lifecycle of data centers.



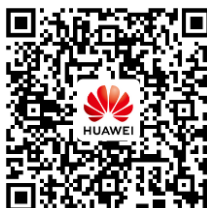

Scan the code for more information

Trademarks and Permissions



and other Huawei trademarks are trademarks of Huawei Technologies Co., Ltd.

All other trademarks and trade names mentioned in this document are the property of their respective holders.

Copyright © 2022 Huawei Digital Power Technologies Co., Ltd. All rights reserved.

No part of this document may be reproduced or transmitted in any form or by any means without prior written consent of Huawei Digital Power Technologies Co., Ltd.

Disclaimer

The information in this document may contain predictive statements including, without limitation, statements regarding the future financial and operating results, future product portfolio, new technology, etc. There are a number of factors that could cause actual results and developments to differ materially from those expressed or implied in the predictive statements.

Therefore, the information in this document is for reference only and does not constitute any offer or commitment. Huawei is not liable for any behavior that you make based on this document. Huawei may change the information at any time without notice.

Huawei Digital Power Technologies Co., Ltd.

Huawei Digital Power AntoHill Headquarters,
Xiangmihu Futian, Shenzhen 518043, P. R. China
digitalpower.huawei.com